

# Activity Report 2019

---

AUTOMATIC CONTROL | LUND UNIVERSITY





**LUND**  
UNIVERSITY

Department of Automatic Control  
P O Box 118, 221 00 Lund, Sweden  
[www.control.lth.se](http://www.control.lth.se)

Annual Report TFRT--4047  
ISSN 0280-5316

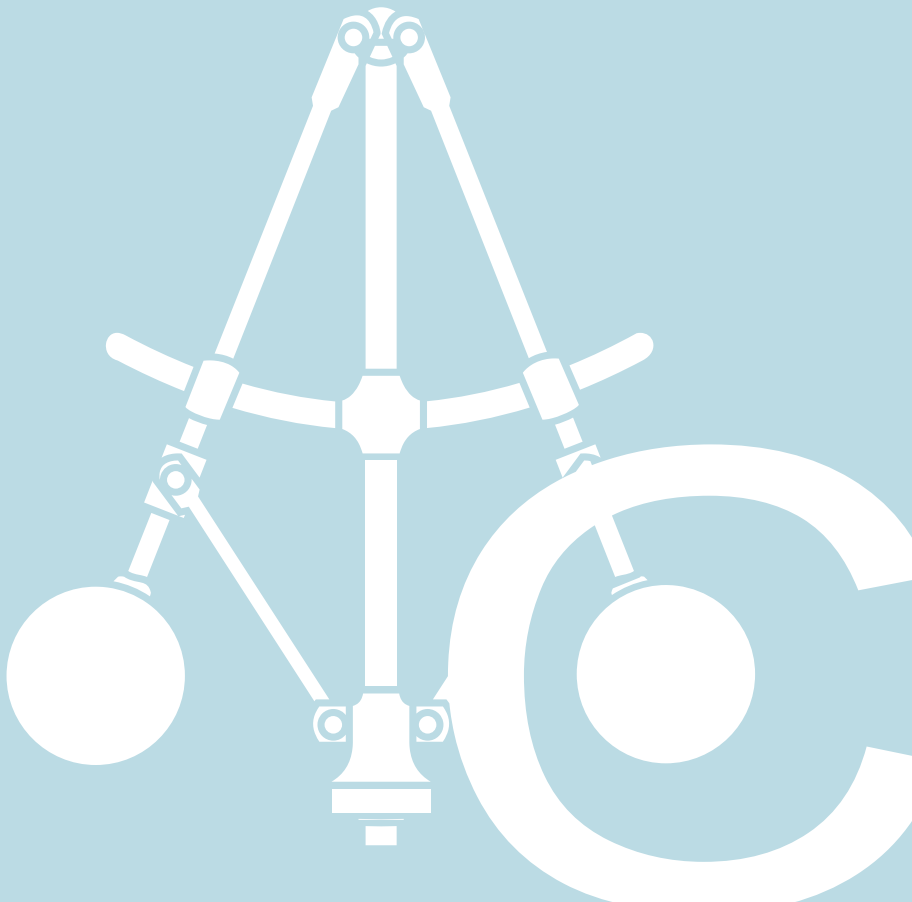



# Activity Report 2019

---



**LUND**  
UNIVERSITY

Department of Automatic Control

### **MAILING ADDRESS**

Department of Automatic Control  
Lund University  
P O Box 118  
SE-221 00 LUND, Sweden

### **VISITING ADDRESS**

Institutionen för Reglerteknik  
Ole Römers väg 1  
223 63 LUND

### **NEW LOCATION 2020 - 2022**

Reglerteknik, location KC4, 3rd floor  
Naturvetarvägen 14  
223 62 LUND

### **TELEPHONE**

+46 46 222 87 87

### **WWW AND GENERIC E-MAIL ADDRESS**

[www.control.lth.se](http://www.control.lth.se)  
[control@control.lth.se](mailto:control@control.lth.se)

Edited by Monika Rasmusson and Karl-Erik Årzén

Printed: Media-Tryck, Lund, Sweden, April 2020

ISSN 0280-5316

Annual Report TFRT--4047



Media-Tryck is a Nordic Swan Ecolabel certified provider of printed material. Read more about our environmental work at [www.mediatryck.lu.se](http://www.mediatryck.lu.se)

**MADE IN SWEDEN** 

# Content

---

<b>Introduction</b> .....	<b>7</b>
AUTOMATIC CONTROL HIGHLIGHTS OF 2019.....	9
<b>Education</b> .....	<b>11</b>
UNDERGRADUATE STUDIES .....	12
GRADUATE STUDIES .....	14
DOCTORAL DISSERTATIONS.....	16
<b>Research</b> .....	<b>21</b>
EXCELLENCE CENTERS AND NATIONAL PROJECTS.....	22
RESEARCH AREAS .....	27
LARGE SCALE SYSTEMS AND LEARNING .....	28
AUTONOMOUS REAL-TIME SYSTEMS.....	32
INNOVATIVE CONTROL APPLICATIONS .....	39
TOOLS AND SOFTWARE .....	57
<b>Publications and seminars</b> .....	<b>59</b>
PUBLICATIONS 2019.....	60
SEMINARS AT THE DEPARTMENT .....	68
<b>External Contacts</b> .....	<b>71</b>
<b>Economy</b> .....	<b>77</b>
ECONOMY.....	78
FUNDING.....	79
<b>Staff</b> .....	<b>81</b>
BOARD OF THE DEPARTMENT .....	83
LONG-TERM VISITORS .....	84
STAFF ACTIVITIES .....	84
PROMOTING GENDER EQUALITY AND DIVERSITY AT THE DEPARTMENT JÄLM@REGLER.....	93
TOGETHERNESS.....	93
AWARDS .....	95
ASSIGNMENTS.....	96
LECTURES BY STAFF OUTSIDE THE DEPARTMENT .....	101





# Introduction

---

A summary of the activities at the Department of Automatic Control, Lund University during the period January 1 to December 31, 2019



## AUTOMATIC CONTROL HIGHLIGHTS OF 2019

This report covers the activities at the Department of Automatic Control during 2019. We can summarise the year in numbers as follows:

The economy showed a turnover for 2019 of 55 MSEK, slightly less than the year before. We are now 48 persons working at the department (guests not included). More about financial figures is found in the chapter *Economy*.

Today the department has 7 professors, 1 senior professor, 2 professors emeriti, 1 adjunct professor, 5 associate professors, 5 research engineers, 4 administrators, 3 post-docs, 3 researchers, 19 PhD students and 3 industrial PhD students. Some of these numbers include part-time positions. During the year, eight new PhD students were admitted to the department. More about this in the chapter *Staff*.

Six PhD theses by Fredrik Bagge Carlson, Gustav Nilsson, Martin Karlsson, Carolina Bergeling, Victor Millnert and Olof Troeng were defended during 2019. The total number of PhDs graduated from the department is now 127. As the previous year, there were no licentiate theses presented.

During the year the department gave 15 different courses to 1 163 students at LTH, and 25 students presented their master theses at the department. For the third year we held the basic course at Beihang University, China, for both Swedish and Chinese students. Teachers and PhD students from our department were responsible for lectures and laboratory exercises. This year video lectures were introduced as well as new labs. Two new courses, *Optimization for Learning* and *Applied Robotics* were introduced.

Among other PhD courses we developed a new course called *Design and Implementation of Cloud Applications* which was given for the first time in September. More about this in the chapter *Education*.

The department's involvement in WASP, the Wallenberg AI, Autonomous Systems and Soft-

ware Program, has increased further during the year. The total number of WASP-funded PhD students at the department is now 11, including three industrial PhD students. Two WASP expedition projects involving the department started during the second semester and within these projects 3 new postdoc positions have been appointed. An ERC Advanced Grant was awarded to Anders Rantzer. This was one of the six ERC Advanced Grants awarded to Swedish researchers during 2019. Two of them ended up at Lund University. The grant amounts to 2.5 MEUR over five years and will be spent on PhD students, postdocs and faculty researchers working on Scalable Control of Interconnected Systems. Read more about our research in the chapter *Research*.

euRobotics week is now well established and took place during three days at the latter part of November. This year there were also three thematic seminars in the intersection between robotics and AI, Connectivity or Automation. This event is visited by Lund surrounding schools and attracts about 400 visitors.

We have welcomed new colleagues and interesting guests. New projects have been contributing to the department, which opens up for new challenges in the years to come. Our department is entering a growing period for the next coming years as we have been fortunate in bringing in new/extended funding.

In the near future we will move to another location as the M-building will be reconstructed during the next 2 years.

*Monika Rasmusson and Karl-Erik Årzén*



# Education

---

Education at undergraduate and graduate level including dissertations 2019

## UNDERGRADUATE STUDIES

The engineering education at LTH follows the central European system with five-year programs leading up to the university degree “civilingenjör”, with the international title MSc.

Automatic control courses are taught as part of the engineering curriculum in Engineering Physics (F), Electrical Engineering (E), Computer Engineering (D), Mechanical Engineering (M), Information and Communication Engineering (C), Environmental Engineering (W), Engineering Mathematics (Pi), Industrial Management and Engineering (I), Biotechnology (B), Engineering Nanoscience (N), Chemical Engineering (K) and Biomedical Engineering (BME). Our advanced courses are included in more than fifteen of the master-level specializations in the various programs. During 2019, two new courses were introduced *Optimization for Learning* and *Applied Robotics*. The department has been involved in LTH’s China Profile for several years and has

taught Automatic Control, Basic Course, at Zhejiang University and, more recently, at Beihang University in Beijing. This year we have introduced video lectures and developed new labs to the course. In 2019, 15 Swedish and 21 Chinese students took the basic control course. Three staff members from the department spent time at Beihang University during the fall.

This year, there were 1163 course registrations and 1 112 passed grades were awarded. The number of registered students corresponds to 150 full-year equivalents. In the table on the next page, our undergraduate courses are listed, along with the number of students who passed each course.

25 students completed their master’s thesis projects, and a total of 19 theses were presented during 2019.

A list of the master theses is given in the *Publications and Seminars* chapter.

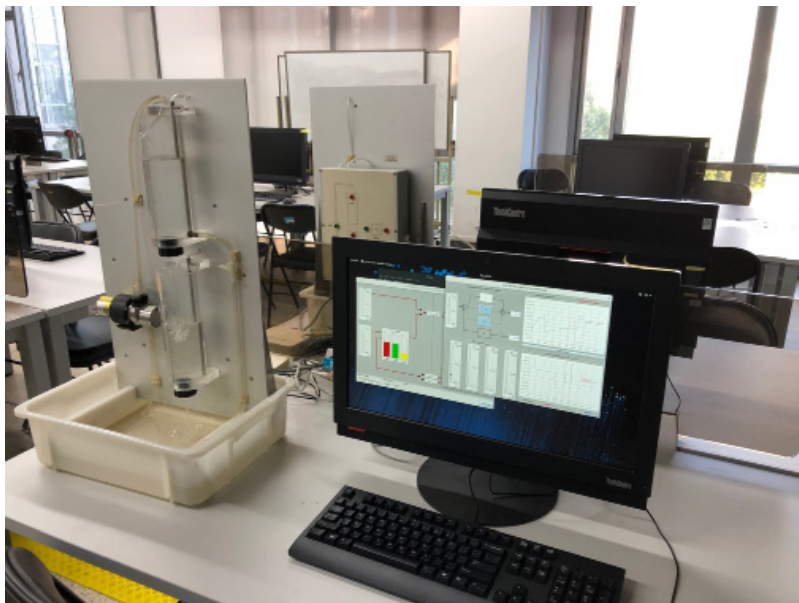

Lab processes in Automatic Control, Basic Course in China

## TOTAL NUMBER OF STUDENTS WHO PASSED OUR COURSES 2019

<b>Automatic Control, Basic Course</b>	
(FRTF05 Reglerteknik AK).....	616
<b>Systems Engineering</b>	
(FRTF10 Systemteknik).....	43
<b>Control Theory</b>	
(FRTF15 Reglerteori).....	5
<b>Applied Robotics</b> <i>NEW</i>	
(FRTF20 Tillämpad robotteknik).....	52
<b>Physiological Models and Computations</b>	
(FRTF01 Fysiologiska modeller och beräkningar).....	36
<b>Real-Time Systems</b>	
(FRTN01 Realtidssystem).....	68
<b>Nonlinear Control and Servo Systems</b>	
(FRTN05 Olinjär reglering och servosystem).....	56
<b>Multivariable Control</b>	
(FRTN10 Flervariabel reglering).....	50
<b>Predictive Control</b>	
(FRTN15 Prediktiv reglering).....	21
<b>Automatic Process Control</b>	
(FRTN25 Processreglering).....	15
<b>Network Dynamics</b>	
(FRTN30 Nätverksdynamik).....	31
<b>System Identification</b>	
(FRTN35 Systemidentifiering).....	16
<b>Project in Automatic Control</b>	
(FRTN40 Projekt i reglerteknik).....	31
<b>Mathematical Modeling, Advanced Course</b>	
(FRTN45 Matematisk modellering, fortsättningskurs).....	30
<b>Optimization for Learning</b> <i>NEW</i>	
(FRTN50 Optimering för maskininlärning).....	42
<b>Research focused training in Automatic Control</b>	
(FRTF93 Forskningsinriktad praktik i reglerteknik).....	4
<b>Degree Project in Automatic Control</b>	
(FRTM01 Examensarbete i reglerteknik).....	25

## GRADUATE STUDIES

The PhD education consists of four years of studies, but since most students have 20% of department duties, the nominal time for the PhD education is 5 years. In the Swedish system there is also a possibility to do a half-time thesis called a "licentiate".

A new general syllabus for PhD studies in Automatic Control is in place. The course requirement for a PhD degree has lowered from 120 to 90 credits, while the thesis scope has increased from 120 to 150 credits. The new syllabus specifies that 30 out of the 90 course credits should be PhD courses in Automatic Control. The course component should also include at least 7.5 credits of general research studies courses. Similar changes are also adopted for licentiate thesis requirements.

In 2019 six doctoral theses were defended by Fredrik Bagge Carlson, Gustav Nilsson, Martin Karlsson, Carolina Bergeling, Victor Millnert and Olof Troeng. We have admitted Johan Grönqvist, Frida Heskebeck, Tauoba Jouini, Olle Kjellqvist, Henry Pigot, Julian Salt Ducaju, Emil Vladu and Birgitta Wingqvist as new PhD students.

A new PhD course, *Design and Implementation of Cloud Applications*, was developed and given for the first time in September. The course was open to WASP students as well as industrial participants. The focus of the course was to understand how to manage infrastructure-as-a-service (IaaS) and design and implement robust and scalable cloud native applications. Course leaders were Johan Eker and Lars Larsson (Umeå University).

The course *Introduction to Research Methodology, Ethics and Innovation for Computing Disciplines*, is also a new course available for PhD students. The course is given by our department together with the Departments of Computer Science and Electro- and Information Technology. The course is divided into three parts; Part1 - *Ethics* was given on October 25, 2019, Part2 - *Research Methodology* was given December 17, 2019, and Part3 - *Innovation* will be given on March 12, 2020.

The Department is also involved as guest speakers in the PhD course *Innovation and Value Creation in Research*.

The following PhD Courses were given in 2019:

- *Study Circle in Reinforcement Learning*; Karl-Erik Årzén
- *Project in Reinforcement Learning*; Karl-Erik Årzén
- *Julia Course*; Mattias Fält, Fredrik Bagge Carlson, Kristian Soltesz
- *Stochastic Control*; Karl Johan Åström, Bo Bernhardsson
- *Topics in Motion Planning and Control*; Anton Shiriaev, Anders Robertsson, Ulrike Thomas
- *Design and Implementation of Cloud Applications*; Johan Eker, Lars Larsson
- *Linear Systems*; Zhiyong Sun
- *Ethics, Research Methodology, and Innovation*; Anton Cervin, Charlotta Johnsson, Emma Söderberg, Martin Höst

Some of the PhD courses were organised within the WASP-AS program, available for both WASP graduate and affiliated students:

- *Autonomous System 1 - Sensing, Perception, Control and Decision Making*
- *Autonomous System 2 - Learning, Knowledge, Interaction and Collaboration*
- *Software Engineering and Cloud Computing*
- *WASP Project Course*



There are some PhD courses organised within the WASP-AI program, available for both WASP graduate and affiliated students:

- *Deep Learning and GANs*
- *Graphical Models, Bayesian Learning, and Statistical Relational Learning*
- *Ethical, Legal, Societal and Economical Aspects of AI*
- *Learning Theory and Reinforcement Learning*
- *Scalable Data Science and Distributed Machine Learning*

## DOCTORAL DISSERTATIONS

This year there were six PhD students defending their theses. The abstracts are presented below and are also available at [www.control.lth.se/publications](http://www.control.lth.se/publications)



Fredrik Bagge Carlson

Carolina Bergeling

Martin Karlsson

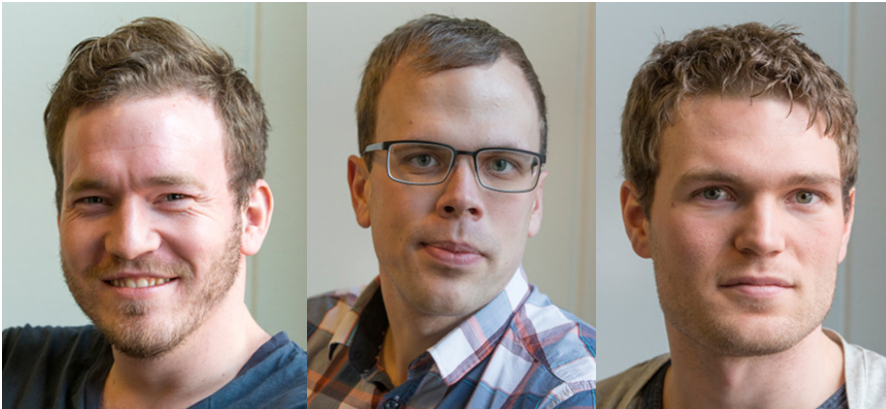

Victor Millnert

Gustav Nilsson

Olof Troeng

## MACHINE LEARNING AND SYSTEM IDENTIFICATION FOR ESTIMATION IN PHYSICAL SYSTEMS

### Bagge Carlson, Fredrik

In this thesis, we draw inspiration from both classical system identification and modern machine learning in order to solve estimation problems for real-world, physical systems. The main approach to estimation and learning adopted is optimization based. Concepts such as regularization will be utilized for encoding of prior knowledge and basis-function expansions will be used to add nonlinear modeling power while keeping data requirements practical.

The thesis covers a wide range of applications, many inspired by applications within robotics, but also extending outside this already wide field. Usage of the proposed methods and algorithms are in many cases illustrated in the real-world applications that motivated the research. Topics covered include dynamics modeling and estimation, model-based reinforcement learning, spectral estimation, friction modeling and state estimation and calibration in robotic machining.

In the work on modeling and identification of dynamics, we develop regularization strategies that allow us to incorporate prior domain knowledge into flexible, overparameterized models. We make use of classical control theory to gain insight into training and regularization while using tools from modern deep learning. A particular focus of the work is to allow use of modern methods in scenarios where gathering data is associated with a high cost.

In the robotics-inspired parts of the thesis, we develop methods that are practically motivated and make sure that they are implementable also outside the research setting. We demonstrate this by performing experiments in realistic settings and providing open-source implementations of all proposed methods and algorithms.

## **ON H-INFINITY CONTROL AND LARGE-SCALE SYSTEMS**

**Bergeling, Carolina**

In this thesis, a class of linear time-invariant systems is identified for which a particular type of H-infinity optimal control problem can be solved explicitly. It follows that the synthesized controller can be given on a simple explicit form. More specifically, the controller can be written in terms of the matrices of the system's state-space representation. The result has applications in the control of large-scale systems, as well as for the control of infinite-dimensional systems, with certain properties.

For the large-scale applications considered, the controller is both globally optimal as well as possesses a structure compatible with the information-structure of the system. This decentralized property of the controller is obtained without any structural constraints or regularization techniques being part of the synthesis procedure. Instead, it is a result of its particular form. Examples of applications are electrical networks, temperature dynamics in buildings and water irrigation systems.

In the infinite-dimensional case, the explicitly stated controller solves the infinite-dimensional H-infinity synthesis problem directly without the need of approximation techniques. An important application is diffusion equations. Moreover, the presented results can be used for evaluation and benchmarking of general purpose algorithms for H-infinity control.

The systems considered in this thesis are shown to belong to a larger class of systems for which the H-infinity optimal control problem can be translated into a static problem at a single frequency. In certain cases, the static problem can be solved through a simple least-squares argument. This procedure is what renders the simple and explicit expression of the controller previously described. Moreover, the given approach is in contrast to conventional methods to the problem of H-infinity control, as they are in general performed numerically.

## **HUMAN-ROBOT INTERACTION BASED ON MOTION AND FORCE CONTROL**

**Karlsson, Martin**

Industrial robots typically require detailed programming and carefully configured work cells to perform well. The large engineering effort implicates high cost and long preparation time, and this is the major obstruction when mediating tasks to robots. The research in this thesis therefore aims to make robot programming faster and more accessible. Methods that allow for programmers to mediate and modify tasks by means of demonstration are presented. Further, robots' abilities to replan with respect to unforeseen changes in their surroundings are enhanced, thus lowering the effort needed for work-cell configuration.

We first consider adjustment of robot movements generated by dynamical movement primitives (DMPs). DMPs are motion-control laws with emphasis on easy modification. For instance, goal configuration and time scale for a certain movement can be updated through one parameter each, commonly without further consideration. In this research, these capabilities are extended to support modifications based on demonstrations through physical human-robot interaction. Further, the motion-control laws are extended to support online replanning for overcoming unforeseen movement deviations.

Subsequently, a method that enables robots to recognize contact force/torque transients acting on the end-effector, without using a force/torque sensor, is proposed. This is achieved using machine learning. The robot is first exposed to examples of force/torque transients. Based on these data, a recurrent neural network (RNN) is trained to recognize such transients. The functionality is used to automatically determine when a robotic subtask is finished, to proceed to the next subtask at the right time. Finally, a control algorithm for teleoperation with force feedback is developed. It allows for an operator to demonstrate movement and forces remotely. One robot arm is moved directly through physical contact with the operator, and a distant robot arm moves accordingly. Interaction forces are reflected to each side of the interface.

Each of the methods presented in this thesis is implemented in a real-time application and verified experimentally on an industrial robot.

## **A TIMELY JOURNEY THROUGH THE CLOUD**

**Millnert, Victor**

This thesis treats the intersection between two of the largest transformations we are seeing within our society today; the cloud and the Internet-of-Things (IoT). The aim of this thesis is to investigate different ways to model and control a network of cloud services so that timing-critical IoT applications can make use of them. Examples of such applications can be autonomous and mobile robots, smart production plants, or massive multi-player augmented-reality games. The main motivational use-case, however, comes from the industrial side, and their digitalization, the drive towards industrial IoT (IIoT). We wish to enable smart robots to offload some of their computations to the cloud in order to allow for better and smarter control and collaboration. For instance, using the cloud, it would become possible for them to collaborate and make use of smarter analytics, artificial intelligence, and machine learning, in order to improve efficiency and safety.

To address this problem the thesis combines concepts and theory from different fields, most notably from control theory, real-time systems, and network calculus. Examples are: modeling of dynamic systems and the use of feedback and feedforward control from control theory, the goal

of ensuring that end-to-end deadlines are met, from real-time systems, and finally the principles of modeling traffic from network calculus.

The thesis begins with an introduction to provide some background on cloud, IIoT, and to set the scope of the thesis. Following this, we begin by treating the problem of controlling a single cloud service with the goal of ensuring that the traffic flowing through the node is guaranteed to meet a deadline. Following this, we study a chain of connected cloud nodes, investigating how to provide end-to-end deadline guarantees for the traffic flowing through the chain. The chain is finally generalized to a network of cloud nodes, with multiple flows traversing it. For this problem we study how to ensure that the end-to-end deadline of every single flow in the network is guaranteed. We also provide a set of protocols controlling how cloud nodes and flows are allowed to dynamically join and leave the network, such that no end-to-end deadline is violated.

## **ON ROBUST DISTRIBUTED CONTROL OF TRANSPORTATION NETWORKS**

**Nilsson, Gustav**

With the ever-growing traffic demands, the transportation networks are getting more and more congested. While expanding these networks with more roads is both costly and in many cities not even feasible, the rapid development of new sensing and communication techniques has made it possible to perform control of transportation networks in real-time. With the right usage of such technologies, existing transportation networks' capacities can be utilized better in order to lower the congestion levels. However, the control has to be done robustly, since real-time control and close to maximal utilization also make the networks more fragile and if not, even a small perturbation can have a tremendous impact on the traffic network. In this thesis, a few solutions that lead to better transportation network utilization are presented, designed with said robustness requirements in mind.

In the first part of the thesis, a decentralized control strategy for traffic signals is presented. The proposed policy, which we call Generalized Proportional Allocation (GPA), is inspired by the proportional fairness allocation for communication networks. The original proportional fairness controller does not explicitly take the overhead time needed to shift between different activation phases into account. We, therefore, enhance the proportional fairness so that it adapts its cycle length to the current demand. When the demand is higher, one wants longer signal cycles not to waste too much of the time overhead, while for lower demands, the cycle lengths should be shorter, so that the drivers do not have to wait for a long time. Stability for an averaged version of this control strategy is proved together with throughput-optimality of the controller. This means that no other control strategy can handle larger exogenous inflows to the network than the GPA-controller. Since the traffic signal controllers such as the GPA may allocate service to an empty line, due to the fact that several lanes can receive green light simultaneously, a model that handles this issue is proposed. For this model, the well-posedness of the dynamical system is shown when the traffic signal controller is Lipschitz continuous.

The GPA controller's performance is also evaluated in a microscopic traffic simulator. In the micro-simulations, it is shown how the proposed feedback controller outperforms the standard fixed-time controller for a scenario based on all traffic over the duration of one full day in Luxembourg. The controller's performance is also compared to another decentralized controller for traffic signals, the MaxPressure controller, for an artificial Manhattan-like network. From these simulations, it can be concluded that the GPA performs better than MaxPressure during low demands, but the MaxPressure

performs better when the demand is high. The fact that the GPA does not require any information about the network, apart from the current queue lengths, makes it robust to perturbations. In other words, the control strategy does not have to be updated when the demand or topology of the network changes.

The second part of the thesis is devoted to routing problems. First, the problem of routing a fleet of vehicles in an optimal way for the whole fleet is considered. The objective is then to achieve a minimum delay in average for the entire fleet. The routing algorithm takes into account the presence of regular drivers that are trying to optimize their own traveling time in the network. Conditions are posted for when such a routing assignment exists, and two algorithms to compute it are shown.

At last, a type of dynamic routing policies for multicommodity flows is studied. The routing policies are designed with the objective to avoid congested routes. It has previously been shown that if only one class of vehicles are present, the network is robust to perturbations with these routing policies. A model for multicommodity flows is proposed, and it is shown that the robustness properties for the single-commodity case do not necessarily hold in the multicommodity case.

## **CAVITY FIELD CONTROL FOR LINEAR PARTICLE ACCELERATORS**

**Troeng, Olof**

High-energy linear particle accelerators enable exploration of the microscopic structure of pharmaceuticals, solar cells, fuel cells, high-temperature superconductors, and the universe itself. These accelerators accelerate charged particles using oscillating magnetic fields that are confined in metal cavities. The amplitudes and phases of the electromagnetic fields need to be accurately controlled by fast feedback loops for proper accelerator operation.

This thesis is based on the author's work on performance analysis and control design for the field control loops of the linear accelerator at the European Spallation Source (ESS), a neutron microscope that is under construction in Lund, Sweden. The main contribution of the thesis is a comprehensive treatment of the field control problem during flat-top, which gives more insight into the control aspects than previous work. The thesis demonstrates that a key to understand the dynamics of the field control loop is to represent it as a single-input single-output system with complex coefficients. This representation is not new itself but has seen limited use for field control analysis.

The thesis starts by developing practical and theoretical tools for analysis and control design for complex-coefficients systems. This is followed by two main parts on cavity field control. The first part introduces parametrizations that enable a better understanding of the cavity dynamics and discusses the most essential aspects of cavity field control. The second part builds on the first one and treats a selection of more advanced topics that all benefit from the complex-coefficient representation: analysis of a polar controller structure, field control design in the presence of parasitic cavity resonances, digital downconversion for low-latency feedback, energy-optimal excitation of accelerating cavities, and an intuitive design method for narrowband disturbance rejection. The results of the investigations in this thesis provide a better understanding of the field control problem and have influenced the design of the field controllers at ESS.

# Research

---

This chapter presents our excellence centers and describes our three main research areas and their ongoing projects

## EXCELLENCE CENTERS AND NATIONAL PROJECTS

ERC - Scalable Control of Interconnected Systems  
 eLLIIT – The Linköping–Lund Initiative on IT and mobile communication  
 WASP – Wallenberg AI, Autonomous Systems and Software Program  
 HI2OT – Nordic University Hub on Industrial Internet of Things

### SCALABLE CONTROL OF INTERCONNECTED SYSTEMS



**Funding: European Research Council - ERC Advanced Grant**

Modern society is critically dependent on large-scale networks for services such as energy supply, transportation and communications. The design and control of such networks is becoming increasingly complex, due to their growing size, heterogeneity and autonomy. A systematic theory and methodology for control of large-scale interconnected systems is therefore needed. In an ambitious effort towards this goal, this project will address the following key aspects:

- Modeling by leveraging tools from learning and adaption
- Control design by utilizing structural properties of the system
- Verification of system performance using decomposable certificates

Energy networks (electricity and district heating) will be used as a guiding example for the development of theory and methodology. Close collaboration with industrial partners will ensure that the research is relevant and useful in practice.





## ELLIIT – THE LINKÖPING–LUND INITIATIVE ON IT AND MOBILE COMMUNICATION

### Funding: Government-funded Strategic Research Area

ELLIIT is a strategic research environment funded by the Swedish government in 2010, as part of its initiative to support strong research in information technology and mobile communications. ELLIIT has four partners: Linköping University, Lund University, Halmstad University and Blekinge Institute of Technology.

ELLIIT constitutes a platform for both fundamental and applied research, and for cross-fertilization between disciplines and between academic researchers and industry experts. ELLIIT stands out by the quality and visibility of its publications, and its ability to attract and retain top talented researchers, and aims at being recognized as a top international research organization.

ELLIIT achieves its goals by a judicious choice of funded focus projects, a structured process for international recruitment, a balanced way of stimulating cooperation between research areas and between the sites involved (LiU, LU, BTH,

HH), and a proactive approach towards fostering and maintaining cooperation with Swedish industry. The overarching objective of ELLIIT is to support scientific excellence in combination with industrial relevance and impact.

The Department of Automatic Control participate in the following ELLIIT projects:

- Co-Design of Robust and Secure Networked Embedded Control Systems
- Collaborative Robotic Systems
- Local Positioning Systems
- Scalable Optimization for Control Systems
- Online Optimization and Control Towards Autonomous Vehicle Maneuvering

During 2019 it was announced that ELLIIT's budget will be increased from 34 MSEK per year to 106 MSEK from 2020 until, at least, 2022. The focus of the expansion is defined by the [ELLIIT 2030 Technology Foresight](#) that was written during 2019.

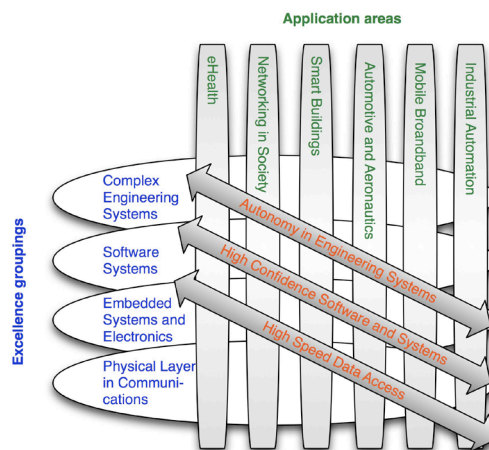

Illustration of the interaction between the themes, the application areas and the groupings (<http://www.liu.se/eELLIIT>)



### **Funding: Knut and Alice Wallenberg Foundation (KAW)**

Wallenberg AI, Autonomous Systems and Software Program (WASP) is Sweden's largest individual research program ever, and provides a platform for academic research and education, fostering interaction with Sweden's leading technology companies. The program addresses research on autonomous systems acting in collaboration with humans, adapting to their environment through sensors, information and knowledge, and forming intelligent systems-of-systems. Software is the main enabler in autonomous systems, and is an integrated research theme of the program. WASP's key values are research excellence and industrial relevance.

The graduate school within WASP is dedicated to provide the skills needed to analyze, develop, and contribute to the interdisciplinary area of AI, autonomous systems and software. The curriculum provides the foundations, perspectives, and state-of-the-art knowledge in the different disciplines taught by leading researchers in the field. Through an ambitious program with research visits, partner universities, and visiting lecturers, the graduate school actively supports forming a strong multi-disciplinary and international professional network between PhD-students, researchers and industry.

The graduate school provides added value on top of the existing PhD programs at the partner universities, providing unique opportunities for students who are dedicated to achieving international research excellence with industrial relevance.

WASP involves seven Swedish universities together with numerous Swedish industries. At Lund University the following four departments participate: Department of Automatic Control,

Department of Computer Science, Department of Electrical and Information Technology, and the Mathematical Imaging Group at the Department of Mathematics.

WASP is currently divided into 12 clusters: Software Engineering for Smart Systems, Autonomous Clouds and Networks, Perception and Learning in Interactive Autonomous Systems, Interaction and Communication with Sensor-Rich Autonomous Agents, Smart Localization Systems, Automated Transport Systems, Large Scale Optimization and Control, Security for Autonomous Systems, Software Technology for Autonomous Systems, AI and Machine Learning for Autonomous Systems, Mathematical Foundations of AI; and Machine Learning, Deep Learning and other AI.

The decision to extend WASP has been recently taken by the board of the Knut and Alice Wallenberg Foundation, and means that the programme, which started in 2015, will continue until 2029 with a total budget of SEK 5.5 billion. The Knut and Alice Wallenberg Foundation (KAW) will provide SEK 4.2 billion, and the remainder will be provided, as previously, mainly from the five partner universities and industry.

A plan for how the expansion will be used is currently under development by the new WASP leadership consisting of Sara Mazur - chair of the WASP board from 1 January 2020 - and Anders Ynnerman - program director for WASP from 1 July 2020.

At the current moment WASP has decided to fund 32 academic PhD students, 15 industrial PhD students, 7 postdocs, 1 full professor, 2 associate professors, 2 assistant professor, 7 professor equivalents for PhD supervision and

research, and 1.5 professor for program management and execution at Lund University. An additional 6 PhD students are currently affiliated with WASP. The department is also involved in the management of WASP. Karl-Erik Årzén is chair of the Program Management Group (PMG) and member of the Graduate School

Management team (GSM), Bo Bernhardsson is member of the Graduate School Management team for WASP-AS (GS-AS), and Anders Rantzer is member of the Program Management team for WASP-AI/MATH (PM-AI/MATH).

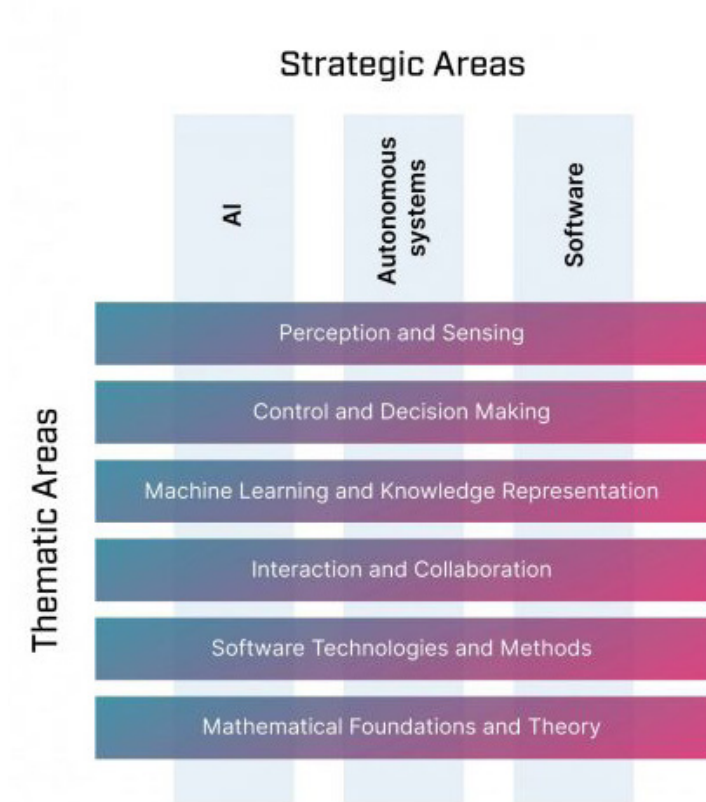

The research in WASP can be illustrated as a matrix with two dimensions, a strategic dimension and a thematic dimension. The strategic dimension emphasizes areas of impact on individuals, society, and industry, whereas the thematic areas represent the underlying scientific and technological challenges that are common to all types of autonomous systems.

The research is conducted at seven Swedish universities: Chalmers University of Technology, KTH Royal Institute of Technology, Linköping University, Lund University, Umeå University, Örebro University, and Uppsala University

## HIZOT – NORDIC UNIVERSITY HUB ON INDUSTRIAL INTERNET OF THINGS

**Reseachers:** Karl-Erik Årzén, Martina Maggio, Anders Robertsson, Anton Cervin, Johan Eker, Tommi Nylander, Per Skarin, Alexandre Martins, Claudio Mandrioli, Nils Vreman, Albin Heimerson, Johan Ruuskanen, Marcus Thelander Andrén, Marcus Greiff

**Partners:** DTU – Technical University of Denmark, Lund University, KTH – Royal Institute of Technology, NTNU – Norwegian University of Science and Technology, Aalto University

**Funding:** Nordforsk - Nordic University Hubs

The overall aim of HI2OT is to promote Nordic collaboration in Industrial Internet of Things (IIoT), which will increase the capacity of the participating organizations and create the critical mass needed to establish a world-leading Nordic research environment on IIoT.

There will soon be 50 billion “smart things” worldwide. When these become interconnected they form the Internet of Things, IoT. Industrial IoT (IIoT) is providing the infrastructure that underpins our Smart Society (Smart Energy Grid, Smart Cities, Smart and Green Mobility, Smart Manufacturing, etc.).

The proposal Nordic University (H)ub on (I)ndustrial (IoT) (HI2OT) is focused on Industrial IoT, a Nordic area of growth and a key technology enabler in solutions to several societal challenges. IIoT will only become a reality through the convergence of Operational and Information Technologies (OT & IT), which are currently separated. This will require multidisciplinary large-scale research effort. Hence, HI2OT brings together the strongest Nordic research groups in IIoT (8 groups at 5 universities) to form a long-term partnership for expanding IIoT cooperation in the Nordic region.

The overall aim of HI2OT is to promote Nordic collaboration in IIoT, which will increase the capacity of the participating organizations and create the critical mass needed to establish a

world-leading Nordic research environment on IIoT. HI2OT provides a unique integration of expertise, generating the synergies required to support the convergence of IT and OT. HI2OT will build a platform and a community to strengthen and structure the IIoT research and innovation. This will enhance national research and innovation systems by increasing their capacity, increase the ability of Nordic nations to address European and global cooperation and competition in IIoT, as well as increasing their competitiveness and growth via research and innovation.

The current Nordic IIoT research efforts are fragmented and address local national industries, lacking the necessary mass to become an international area of excellence. Research infrastructures are not cost-efficient, and will require the pooling of resources through increased coordination. HI2OT will build a platform and a community to strengthen and structure the IIoT research and innovation. HI2OT fits perfectly with the objectives of the participating universities, who have explicit IIoT strategies and strategies for Nordic cooperation. HI2OT will enhance the competitiveness of participating institutions, strengthen national research and innovation systems by increasing their capacity, and increase the ability of Nordic nations to address European and global cooperation and competition in IIoT.

## RESEARCH AREAS

The goal of the department is to provide students with a solid theoretical foundation combined with a good engineering ability. This is reflected in the research program which covers both theory and applications. The research activities can roughly be divided into three thematic areas:



### LARGE-SCALE SYSTEMS AND LEARNING

What do traffic networks, wind farms, Facebook and economic markets have in common? They are all large-scale networked systems, which can be analyzed and optimized using automatic control techniques.



### AUTONOMOUS REAL-TIME SYSTEMS

Their vision? To create user-friendly, self-adaptive, resilient, high-performing systems, with low latency and jitter, while being cost-effective.



### INNOVATIVE CONTROL APPLICATIONS

This is an area of application-driven research motivated by the desire to create a more sustainable society. It addresses several of the UN's 17 Sustainable Development Goals.

## LARGE SCALE SYSTEMS AND LEARNING

What do traffic networks, wind farms, Facebook and economic markets have in common? They are all large-scale networked systems, which can be analyzed and optimized using automatic control techniques. By developing scalable methods for control and optimization, researchers at the Department of Automatic Control are contributing to solving one of the greatest challenges in modern engineering - the sustainable and safe operation of these large-scale systems.

A significant part of this field of research is directed towards developing theories and methodologies supporting the design and verification of distributed control structures. Other important parts focus on combining classical physics-based models with machine-learning tools, and combining models for traditional networks, for example, for electricity and heating, with learning algorithms for consumer behavior and decision-making. The aim is to improve efficiency and reliability, while at the same time reducing costs.

**One of our PhD students within this field were doing research together with the Pasteur Institute in France and defended his work in late 2018. Below is a summary of his research.**

### **Systems Immunology - Health in the Digital Age**

Have you ever wondered why you get sick much more often than your colleagues or fellow students? You may soon know the answer. Researchers at the Department of Automatic Control, together with researchers at the Institut Pasteur in France, are currently transferring the knowledge obtained from large-scale data analysis into the field of immunology, paving way for a unique kind of precision medicine, and contributing to a whole new field of research – systems immunology.

Using data from 1 000 healthy French citizens (500 women and 500 men, aged 20 to 70 years), Jacob Bergstedt, a former PhD student at the Department of Automatic Control, and currently a postdoctoral fellow at the Institute Pasteur, has looked deep into the human genome, in an attempt to find out which factors influence our immune system most, and how these factors interact. Together with his colleagues at the Institut Pasteur, Etienne Patin, Lluís Quintana-Murci, and Matthew Albert, he has analyzed 166 different variables in the human immune system, more than 6 million genetic mutations, and a number of clinical and demographical parameters, such as age, gender, obesity, sleep patterns, education, and smoking. Handling such large data sets is not an easy task. "It requires not only more sophisticated analysis, but also much better software than previously used", says Jacob Bergstedt. A fundamental issue associated with the analysis is that of statistical misconceptions. "When looking for causation in these huge data sets, one has to be very careful not to infer causal relations from statistical correlations", says Bo Bernhardsson, professor at the Department of Automatic Control and Jacob Bergstedt's main supervisor. To ensure that the French dataset was handled in an adequate manner, a so-called causal model was developed. "We combined old computation tools, some of them originally developed within machine learning and artificial intelligence, with new tools that we developed ourselves, in order to find ways to accurately analyze this rich and complex collection of data", says Jacob Bergstedt.

## Our environment affects us

So what were the most important results of their analyses? They found significant differences in the functioning of the immune system between men and women, and that environmental factors have a significantly greater impact on our immune system than previously realized. One example is smoking. It is well known that smoking constitutes a risk factor for infections. However, Jacob Bergstedt's analyses showed that it has as great an impact on the immune system as age. "This is a completely new discovery", he says.

One of the most apparent gender differences was that women produce significantly more T-cells than men during adult life. T-cells are one of the most important components of the immune system, and the increased production in women may explain why women generally have less risk of infection than men. Furthermore, Jacob Bergstedt and his colleagues found that the elevated levels of T-cells in women could be further amplified by one of the many mutations they studied. Apart from their higher production of T-cells, women also produce higher levels of so-called MAIT cells – a special type of T-cells – which have been connected to autoimmune diseases. The researchers speculated that this overproduction of MAIT cells in women may explain why middle-aged women are more afflicted by autoimmune diseases than men.

Apart from smoking, age, and gender, infection by cytomegalovirus (a common herpes virus) was among the most influential factors with regard to infection. "This is a relatively common virus, which seems to have a greater impact on our health than previously thought", says Bo Bernhardsson.

The group now hopes that other medical institutes will make data available for analysis, to benefit more patients. "This type of refined analysis provides broader knowledge on individual prerequisites, which will ultimately help us develop more customized health care", says Bo Bernhardsson.

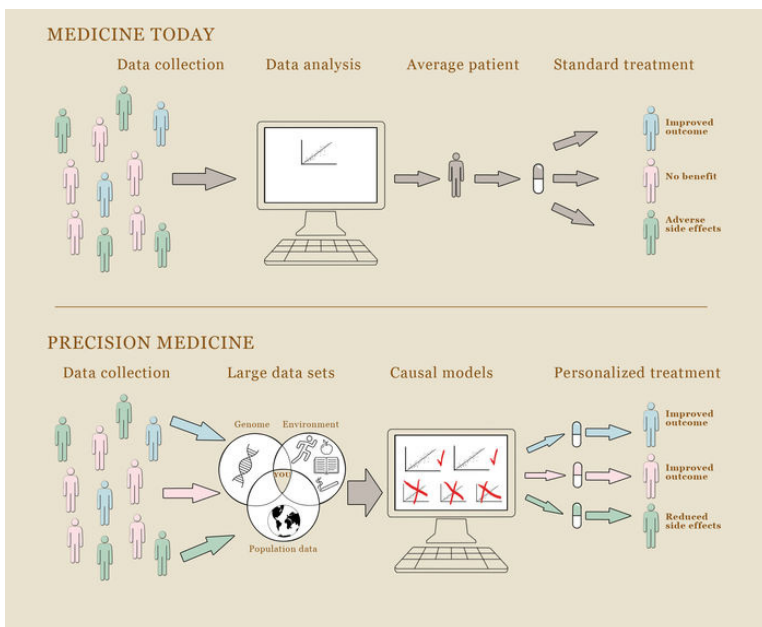

**Ongoing projects:**

- Dynamics, Information and Control in networks
- Learning and Adaptation
- Large-Scale Convex Optimization

**DYNAMICS, INFORMATION AND CONTROL IN NETWORKS**

**Researchers:** Carolina Bergeling, Martin Heyden, Gustav Nilsson, Richard Pates, Giacomo Como, Anders Rantzer

**Funding:** VR and SSF

Large-scale networks play a constantly increasing role in our modern society, e.g., affecting the access to essential services like mobility and energy, influencing the outcome of electoral polls, and determining the quality of the economic system.

The Department hosts a research group on Dynamics, Information, and Control in Networks. The focus of this group is on the mathematical foundations of large-scale network systems with particular emphasis on issues related to their resilience, centrality, and scalability. Applications include cyber-physical systems, transportation networks, as well as social and economic networks.

One project is focused on transportation networks, with publications about decentralized traffic signal control and distributed dynamic tolls.

Another project studies the interplay between economics and traffic flows in transport networks. We will study exchange equilibria in traffic networks and network dynamics in presence of human decision makers. The goal is to gain deeper understanding of, and be able to exploit, the interaction between node demands and network flows.

**LEARNING AND ADAPTATION**

**Researchers:** Johan Grönqvist, Christian Rosdahl, Olle Kjellqvist, Frida Heskebeck, Carolina Bergeling, Bo Bernhardsson, Anders Rantzer

**Funding:** WASP and ERC

There are many important applications where classical physics based models need to be combined with machine learning tools. A good example is in autonomous driving, where automotive industry have extensive experience of control technology such as ABS braking, cruise control and ESP systems for vehicle stabilization. This technology now needs to be combined with

machine learning methods to analyze traffic situations and human behavior. To do this in a safe and robust manner, it is essential to understand how learning algorithms for discrete sequential decision-making can interact with continuous physics based dynamics. Many other applications can be found. In the energy sector, well established control solutions for power networks



and generators are increasingly being combined with learning algorithms for consumer behavior and decision-making, to minimize costs and optimize efficiency. In medicine, standard practice for disease therapies is combined with expert systems and sequential decision-making for medical diagnosis.

In our collaboration project with Alexandre Proutiere at KTH the aim is to bridge the gap between machine learning and control engineering. These research fields have traditionally evolved more or less separately, but in recent years the intersections in terms of applications as well theoretical challenges have been growing. This project is concerned with sequential decision making in systems whose dynamics are

initially unknown, i.e., with adaptive control or reinforcement learning. Statistical models are of fundamental importance in both areas, but while learning theory has been focused on sample complexity and regret, the corresponding control literature is discussing stability robustness and asymptotic performance. An important focus of our project is the tradeoff between exploration and exploitation, sometimes known as “dual control”. The optimal tradeoff strategy can be formulated as the solution to a dynamic programming problem. We study properties of the solution as well as computational schemes. Optimal strategies are compared with common heuristics, both in control and reinforcement learning.

## LARGE SCALE CONVEX OPTIMIZATION

**Researchers: Pontus Giselsson, Mattias Fält, Martin Morin, Hamed Sadeghi, Sebastian Banert and Mustafa Yetis**

### **Funding: VR and WASP**

Convex optimization is a useful tool in many fields. It is used in signal processing, statistical estimation, control, medical imaging, and machine learning. Many of these applications give rise to optimization problems of large dimension. There is a great need for software and algorithms that efficiently and robustly can solve large-scale optimization problems. Traditional state-of-the-art methods such as interior point methods do not scale well with dimension. Even one iteration may be computationally infeasible to perform for large enough problems. Therefore, first-order methods such as proximal and projected gradient methods, forward-backward splitting, Douglas-Rachford splitting, the alternating direction method of multipliers, primal-dual methods such as Chambolle-Pock, and their stochastic, reduced variance, and coordinate-wise variations, are typically used in the large-scale regime. The reason is that the computational cost of one iteration in a first-order method

grows more gracefully with problem dimension. However, the number of iterations in a first-order method may be significant.

One of the main directions in our research group is to devise first-order algorithms with low per iteration cost that converge in fewer iterations than existing methods. To achieve this goal, a good understanding of existing methods is needed. We therefore also focus on existing algorithm analysis. The traditional way of analysing algorithms is to manually combine inequalities and equalities that describe the algorithm and the operations used in the algorithm such as gradient steps and proximal steps. We are developing methods and computer tools that can automate this analysis process. The automated tools will be able to find Lyapunov functions, that can be used to conclude algorithm convergence, as well as finding sharp rates of convergence for a given Lyapunov function.

### AUTONOMOUS REAL-TIME SYSTEMS

A significant part of the research in this field revolves around cyber-physical systems, clouds, and cloud control. Historically, control systems have been deployed as monolithic software implementations on carefully tuned hardware, adjacent to the plants they control. This has resulted in systems that are undesirably non-modular, not easily extensible and that have limited ability to self-adapt. In contrast, feedback-based cyber-physical systems and cloud-native applications offer the prospect of greater accessibility and flexibility, as well as higher reliability and lower latencies. Furthermore, when applications are implemented in a disaggregated manner, their execution can be distributed across the system's many nodes, migrated, and scaled to meet individual objectives as well as that of the system as a whole.

**We have collaborations in this field with industry and colleagues that work both at the university and in industry - below is an example of such collaboration together with Ericsson.**



#### **Industry + Academia = A Perfect Match**

A substantial part of the research performed within Autonomous Real-Time Systems at the Department of Automatic Control is carried out in close cooperation with industry. Johan Eker is one of several researchers dividing his time between academia and industry.

"I get the best of both worlds by combining the two", he says.

He likes distinct clients, the substantive issues, and the high tempo at Ericsson, where he is employed as a principal researcher, as well as the possibilities for reflection and of immersing himself in a subject at the University, where he has the position of adjunct professor.

"Within my field of research, which is 5G and industrial clouds, industry is at the technical leading

edge. We gain a lot of momentum for our more theoretical approaches within the University by cooperating with industry.”

Johan Eker uses the manufacturing industry as an example. Companies are introducing data-driven solutions to increase competitiveness, by improving quality and avoiding unscheduled interruptions. This generally involves augmenting the feedback control loops. These automation loops require a low and predictable end-to-end latency, making it unfeasible to use services that reside in a cloud infrastructure, due to the current lack of these features in the cloud. However, with the new technology that 5G promises, it will be possible to establish a low-latency connection between the automation application and the cloud infrastructure hosting the services. While the industrial partner, Ericsson in this case, looks deeper into the practical aspects of establishing a cloud infrastructure that works well, researchers at the University are performing in-depth studies on the theory behind resource availability, and suggesting models to scale computing power depending on demand.

“We’re trying to find out how to make a system elastic, while still being reliable and predictable”, says Johan Eker.

#### Ongoing projects:

- Autonomous Cloud
- Autonomous Datacenters – AutoDC
- Co-Design of Robust and Secure Networked Embedded Control Systems
- Event-Based Control of Stochastic Systems with Application to Server Systems
- Event-Based Information Fusion for the Self-Adaptive Cloud
- Testing of Autonomous Systems

## AUTONOMOUS CLOUD

**Researchers: Karl-Erik Årzén, Martina Maggio, Johan Eker, Tommi Nylander, Per Skarin, Alexandre Martins, Victor Millnert, in collaboration with the Department of Electrical and Information Technology at LTH, Umeå University, and KTH.**

### Funding: WASP

#### Background

An increasing amount of computing and information services are moving to the cloud, where they execute on virtualized hardware in private or public data centers. Hence, the cloud can be viewed as an underlying computing infrastructure for all systems of systems. The architectural complexity of the cloud is rapidly increasing. Modern data centers consist of tens of thousands of components, e.g., compute servers, storage servers, cache servers, routers, PDUs, UPSs, and

air-conditioning units, with configuration and tuning parameters numbering in the hundreds of thousands. The same increasing trend holds for the operational complexity. The individual components are themselves increasingly difficult to maintain and operate. The strong connection between the components furthermore makes it necessary to tune the entire system, which is complicated by the fact that in many cases the behaviors, execution contexts, and interactions are not known a priori. The term autonomous

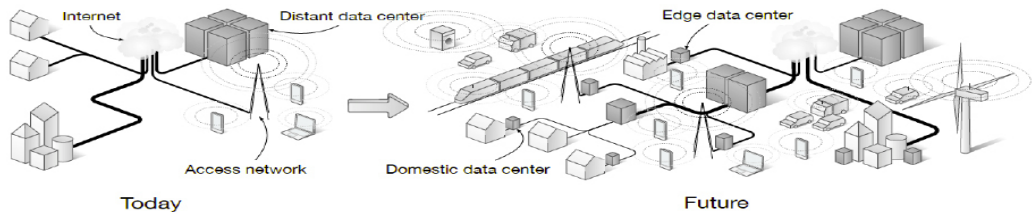

The following figure illustrates how the computations in the distributed cloud are migrating from back-end data centers out in the network.

computing or autonomic computing was coined by IBM in the beginning of the 2000s for self-managing computing systems with the focus on private enterprise IT systems. However, this approach is even more relevant for the cloud. The motivation is the current levels of scale, complexity, and dynamicity which make efficient human management infeasible. In the autonomous cloud control, AI, and machine learning/analytics techniques will be used to dynamically determine how applications should be best mapped onto the server network, how capacity should be automatically scaled when the load or the available resources vary, and how load should be balanced.

Currently there is also a growing interest in applying cloud techniques, such as virtualization and collocation, in the access telecommunication network itself. The unification of the telecom access network and the traditional cloud data centers, sometimes referred to as the distributed cloud, provide a single distributed computing platform. Here the boundary between the network and the data centers disappears, allowing application software to be dynamically deployed in all types of nodes, e.g., in base stations near end-users, in remote large-scale datacenters, or anywhere in between. In these systems the need for autonomous operation and resource management becomes even more urgent as heterogeneity increases, when some of the nodes may be mobile with varying availability, and when new 5G-based mission-critical applications with harder requirements on latency, uptime, and availability are migrated to the cloud.

### Project outline

In the project distributed control and real-time analytics will be used to dynamically solve resource management problems in the distributed cloud. The management problem consists of deciding the types and quantities of resources that should be allocated to each application, and when and where to deploy them. This also includes dynamic decisions such as automatic scaling of the resource amount when the load or the available resources vary, and on-line migration of application components between nodes. Major scientific challenges include dynamic modeling of cloud infrastructure resources and workloads, how to best integrate real-time analytics techniques with model-based feedback mechanisms, scalable distributed control approaches for these types of applications and scalability aspects of distributed computing.

In order to develop efficient methods for resource management, it is crucial to understand the performance aspects of the infrastructure, what the workloads look like, and how they vary over time. Hence, Infrastructure modeling and Workload modeling for the distributed cloud are important topics. Due to user mobility and variations in usage and resource availability, applications using many instances are constantly subject to changes in the number of instances; the individual instances relocated or resized; the network capacity adjusted; etc. Capacity autoscaling is needed to determine how much capacity should be allocated for a complete application or any specific part of it; Dynamic

component mapping to determine when, where, and how instances should be relocated, e.g., from a data center to a specific base station; and Optimized load mix management to determine how to “pack” different instances on individual servers or clusters. Since not all applications are equally important, e.g., due to differently priced service levels or due to some being critical to society (emergency, health care, etc.), the solutions to the three problems above must take into account Quality of Service differentiation. Finally, we address Holistic management to perform full-system coordination.

The primary software infrastructure will be based on Calvin, an open source application environment developed by Ericsson and aimed at distributed clouds for IoT services. Calvin

is based upon on the well-established actor model, it scales well, and it supports live migration of application components. We believe this infrastructure is suitable to investigate the application performance behavior of future commercial systems and validate our developed management solutions. It will enable accurate estimations of, for example, application latency and system loads.

The project results have the potential to be demonstrated in several WASP demonstrator arenas, including the Autonomous Research Arena (ARA), the Ericsson Research Data Center (ERDC); as well as in different university lab facilities.

## **AUTONOMOUS DATACENTERS – AUTODC**

**Researchers: Karl-Erik Årzén, Johan Eker and Albin Heimerson, in collaboration with KTH, Luleå University, Aalto University, Ericsson, RISE, and twelve other partners**

### **Funding: Vinnova**

With growth in the data centre market expected to continue, the cost of operating and maintaining the data centre footprint will increase. The aim of AutoDC is to provide an innovative design framework for autonomous data centres to enable ongoing operation and self-healing independent of contextual interference, e.g. intermittent power failure or overheating, without the need for any human intervention. Due to lower maintenance and operation costs, autonomous data centres can become key enablers of markets in developing countries.

The AutoDC project is led by Tor Björn Minde, Ericsson and consists of the following partners:

- Austria: AICo Software, Fluxguide
- Canada: Ericsson, Mariner Partners, Missing Link Technologies, Saint Mary’s University
- Finland: Aalto University, Granlund Oy, kW-set Oy, Orbis Oy
- Sweden: 5 High Innovations, Clavister, Comsys, Ericsson, KTH, Luleå University of Technology, OP5, RISE, Swedish Modules, Swegon Operations

## CO-DESIGN OF ROBUST AND SECURE NETWORKED EMBEDDED CONTROL SYSTEMS

**Researchers:** Nils Vreman, Martina Maggio, Anton Cervin, Karl-Erik Årzén, Gautham Nayak Seetanadi, Marcus Thelander Andrén in collaboration with Linköping University

**Funding:** eLLIIT

In the design of embedded control systems it is important to use the limited platform resources (e.g., CPU time, network bandwidth, energy) as efficiently as possible. At the same time, any optimistic assumptions at design time may lead to runtime failures caused by missed deadlines, lost controls, or energy depletion. Shifting our focus from off-line optimization to on-line operation, in this project we aim to develop theory and co-design methodology for robust and secure embedded control systems that should operate efficiently also in the presence of uncertainties or unforeseen events. We will consider both passive and active robustness towards, among other things, plant perturbations, malicious intrusion, execution-time overruns, and varying network capacity. In the passive approach, we aim for techniques that take parametric plant and platform uncertainty into account at design time, while the run-time system should provide predictable exception handling and provable

performance bounds. In the active approach, the run-time system should be able to adapt to new and unexpected conditions via reconfiguration and self-optimization.

During 2019 we have investigated overrun handling methods for feedback controllers executing under the logical execution time paradigm. By co-designing the controller parameters, the sampling period, and the overrun strategy, we can achieve better control performance and higher average utilization than traditional, conservative approaches. We have also developed a new Matlab-based toolbox, called JitterTime, for analyzing how jitter, packet drops, task overruns, and other transient problems in feedback loops affect the control performance. The toolbox has been used to evaluate the effect of deadline overruns (see above) as well as to optimize static schedules for distributed controllers implemented in the edge cloud.

## EVENT-BASED CONTROL OF STOCHASTIC SYSTEMS WITH APPLICATION TO SERVER SYSTEMS

**Researchers:** Marcus Thelander Andrén, Anton Cervin, Bo Bernhardsson, Kristian Soltesz

**Funding:** VR

With the current strong trend towards networked and autonomous systems, it becomes less realistic to demand that all elements of a control loop should operate in a synchronous, time-triggered fashion. Above the lowest level of feedback control, it is often more natural and efficient to communicate, decide, and act based on events. Previous work shows that event-triggered control can achieve both lower average

sampling rates and better performance than standard, periodic control. There is however not yet a coherent theory for analysis and synthesis of event-based controllers.

The aim of this project is to develop theory, tools, and design methodology for event-based control of stochastic systems. The overall goals are more efficient resource usage and better performance compared to standard sampled-

data control. At the same time, the methods are aimed at a wider class of control problems, including those that combine local feedback with higher-level decision making. Such features are common in various applications such as autonomous vehicles, traffic routing, control of computing systems, supervisory plant control, and resource management in the cloud.

During 2019 we have continued the investigation of finding the LQG-optimal sampling policy for a given event-based controller structure.

The focus has been on developing numerical approximations to the optimal solution that can be applied to higher-dimensional systems. In a parallel line of work, we have looked at the connection between LQG-optimal and heuristic event-based PID controllers. Inspired by the optimal solution for a given second-order plant, we propose a new of implementing the simple event-based PID controller.

## EVENT-BASED INFORMATION FUSION FOR THE SELF-ADAPTIVE CLOUD

**Researchers: Johan Ruuskanen, Anton Cervin, Karl-Erik Årzén**

### **Funding: WASP**

Successful self-adaptive resource provisioning in the cloud relies on accurate tracking of workload variations and timely detection of changes in the infrastructure. The general estimation problem is very challenging due to the massive number of observable events in various subsystems, each containing some useful information. In this project, we will develop novel, event-based estimation techniques for information fusion in cloud server systems. Our starting point will be the family of Monte Carlo-based inference methods known as Particle Filters, which will be adapted to handle event-based measurements from different sources and with different time scales. The results will enable more responsive and exact decision making in the autonomous cloud.

During 2019 we have studied how particle filtering techniques can be adapted to bet-

ter handle event-based measurements. The resulting auxiliary particle filter uses a Gaussian mixture model to track the non-Gaussian state distribution at all times and does not suffer from the particle degeneracy problem at measurement events. We have also researched how innovation-based event triggering can be exploited for nonlinear systems under remote estimation, where it is shown to outperform simpler techniques such as send-on-delta. In the resulting energy-saving scheme, a sequence of trigger conditions are precomputed in the remote observer and only transmitted to the sensor after each measurement event. In a parallel line of work, we have also started to develop a testbed for experimenting with scalable cloud applications.

## TESTING OF AUTONOMOUS SYSTEMS

**Researchers:** Claudio Mandrioli, Martina Maggio

**Funding:** WASP

Many cyber-physical systems change their behaviour depending on environmental data and internal states. This is the case of control systems, that compute a control signal that depends on input values like a desired position, measured values like the current position, and internal states like the previous control action. This is also the case of systems embedding machine learning algorithms, that receive new samples and incorporate what they learnt using these new samples into a policy that determines how to behave in new conditions. All these systems are adaptive, in that their behaviour changes over time in a prescribed - but a priori unpredictable - way. This project is about testing and comparing systems that incorporate some adaptivity.

Testing systems whose behaviour varies over time is difficult. Think of a machine learning algorithm: how many and which samples should we give to the system before we can consider its behaviour testable? And what is the correct outcome? Of course we can apply unit testing to each function in the code, check for coverage, select a few cases in which the ideal behaviour of the code is known. But this does not give us any guarantee that the code is behaving correctly for the task it has to complete in the physical environment.

We advocate that a formal and rigorous methodology is needed to test systems with adaptivity like self-adaptive software. This methodology should be used in conjunction with other forms of testing (e.g., unit testing) to pro-

vide guarantees on the cyber-physical system behaviour.

When learning is involved, it is impossible to provide any deterministic guarantees, since the function to be learnt may not have been explored. In such cases, drawing any general conclusion is impossible (and undesirable), unless probabilistic guarantees are targeted. We are convinced that this is true also for adaptive software and a paradigm shift is necessary for its testing: guarantees deriving from the tests' execution should be provided in the probabilistic space rather than in the deterministic one.

In the probabilistic space, we plan to investigate three alternatives methods to analyze testing data and provide guarantees:

- Monte Carlo experiments
- Extreme Value Theory
- Scenario Theory

### Progress

Since the project start in 2018, the first activity has been the investigation of the theoretical tools that can be used, with a particular focus on the scenario theory. Secondly, we implemented a simulated infrastructure for testing a self-adaptive application (the Tele Assistance System) in Matlab. We plan to use this as a benchmark example to illustrate our ideas.



### INNOVATIVE CONTROL APPLICATIONS

This is an area of application-driven research motivated by the desire to create a more sustainable society. It addresses several of the UN's 17 Sustainable Development Goals. It also has an impact on LTH's five core research areas, meaning that this field of research is important in digitalization, industry, the built environment, our climate, and life itself.

Numerous applications are being addressed, for example, within robotics, health care, the process industry, combustion engines, and smart manufacturing. A substantial part of the research takes place in the robotics lab. Apart from research on automatic control, this focus area also concentrates on teaching and learning methods, standards for smart industries, and innovation indexes.

Much of the research is performed in collaboration with, and is co-funded by, industrial partners.

**Our research is found in many different areas. One of our former PhDs did research within the medical technology field together with British Columbia Children's Hospital in Canada.**

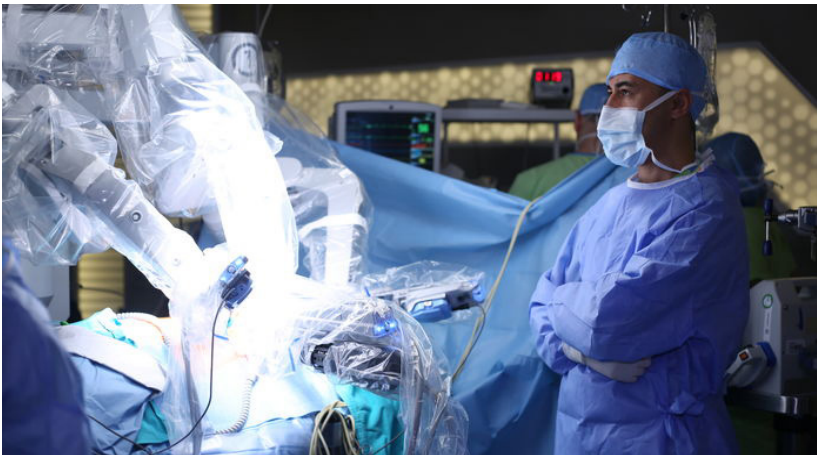

#### **From Algorithms to Anesthesia**

When Kristian Soltesz, currently a researcher at the Department of Automatic Control, was a PhD student, he went to Canada to carry out a project on the automatic control of paper mills.

"When I arrived, the professor asked me if I would consider working on medical applications instead, such as the anesthesia of patients during surgery."

A strong team of engineers, doctors and research assistants at the University of British Columbia (UBC) and the British Columbia Children's Hospital convinced Kristian Soltesz, so he applied for research money, and got it.

The aim of Kristian Soltesz' project was to automate the control of anesthesia normally provided by the anesthesiologist. Anesthesia is currently administered to patients completely manually. The anesthesiologist assesses the anesthetic state of the patient using clinical monitoring, for example, heart rate and blood pressure, as well as patient signs, such as response to speech, eyelash reflex and breathing pattern, and adjusts the dosage accordingly. Kristian Soltesz and his colleagues wanted to create models that could be used in the development of computerized algorithms.

"Researchers at UBC had already developed sensors to measure the brain activity of patients, which is correlated to their degree of consciousness", says Kristian Soltesz and continues:

"My task was to develop mathematical models for the administration of anesthetic drugs before and during surgery, where the drug infusion rate is continuously adjusted depending on the response of the individual patient."

### **Automatic control of anesthesia was a success**

In their first study, they investigated the effect of automatic closed-loop control of anesthesia on 102 children aged 6-17 years undergoing endoscopic investigations.

"It was a success. Our system achieved and maintained an adequate degree of anesthesia in 85 percent of the patients, which shows that it is possible to control anesthesia in children using a rather simple controller and minimal intervention", says Kristian Soltesz.

Numerous clinical studies and a multitude of publications have since proven the method to be both robust and safe, enabling the anesthesiologist to simultaneously supervise more patients. Even more importantly, drug dosage is expected to decrease, and post-operative recovery to be faster, as the patients are monitored more closely, and drug doses better adjusted.

Closed-loop-controlled anesthesia is now awaiting approval from agencies such as the US Food and Drug Administration.

"Getting research money to start this project has been invaluable to me. My PhD thesis is largely based on the research performed during the two years in Canada, and it has been decisive in my current research in organ preservation", says Kristian Soltesz.

#### **Ongoing projects:**

- Robotics Lab
- The Surgeon's Perspective
- Semantic Mapping and Visual Navigation for Smart Robots
- Autonomous Flight (LUAV@Lund)
- Control of the European Spallation Source
- Closed-Loop Combustion Control
- Decentralized Control Structures for Process Control
- Anesthesia in Closed-Loop
- Industrial Cloud Sandbox
- Hemodynamic Stabilization
- Ventilator for Improved Cardiopulmonary Resuscitation
- Strategies and Standards for Smart Swedish Industry
- Mind Methodology
- On Humans for Humans
- Real-Time Individualization of BCIs

## ROBOTICS LAB

The Robotics Lab at LTH is an experimental arena shared by the Department of Automatic Control and the Department of Computer Science. Robotics is a multi-disciplinary topic, and we collaborate with both national and international robotics colleagues regarding different aspects of robotics and we also have a close cooperation with industrial partners. Our main research is in motion and compliance control, control system architectures and different sensor fusion problems with application mainly to industrial manipulators. We mainly use modified industrial robot control systems and UAVs as experimental platforms.

The purpose of past and present research projects is to show how to organize open robot control systems and to verify these ideas by means of experimental verification. As a part of this research, we have developed several experimental open robot control systems. The systems are built around industrially available robots that have been reconfigured for experimental purposes.

The developed specific robot interfaces and the integration of the robots into a complete system forms a unique environment for testing and development of algorithms for improvement of performance, sensor integration, programming automation and autonomous operation. New sensor interfaces with modification of hardware and realtime software architectures have been developed to accommodate the use of force control algorithms based on workspace sensing. The research in this area has been awarded with e.g., the EURON Technology Transfer award and an ICRA Best Automation paper.

Current robotics-related projects at the department include:

- Construction Robotics of Today and Tomorrow
- The Surgeon's Perspective
- Mapping and Visual Navigation for Smart Robots
- Autonomous Flight

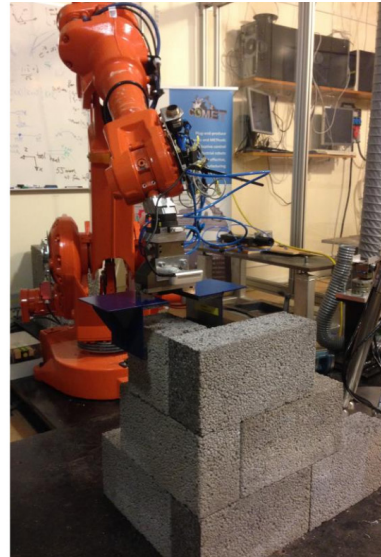
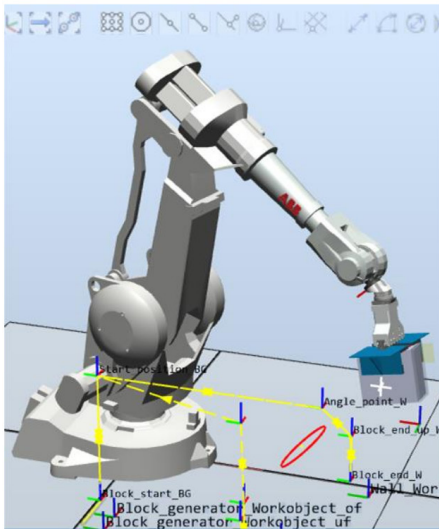

## CONSTRUCTION ROBOTICS OF TODAY AND TOMORROW

**Researchers: Anders Robertsson, Rolf Johansson, Manuel Korell and colleagues from the Department of Computer Science Maïke Klöckner, Mathias Haage.**

**Funding: Boverket and Vinnova**

Since a couple of years new activities within construction robotics have started at LTH and a new cross-disciplinary laboratory facility is under establishment in the V-buiding, LTH, with serial and parallel kinematic robots for use in building construction, large structure 3D-printing etc.

### Ongoing collaboration projects are

- Innovative Construction with Flexible Robot-Human Interaction (Boverket)
- Innovative Agile Construction for Globally Improved Sustainability (ACon 4.0) (VINNOVA UDI-2)

### Purpose and goal

The construction industry has major problems linked to productivity, building quality, gender equality & safe work environment and environmental impact. Today's tools are developed to support existing value chains and building systems, and can be seen as part of the sector's problems. The ACon project will develop and develop solutions in construction by (i) reducing the current fragmentation of the construction industry (ii) link digital design to production automation (iii) develop safer and more equal

workplaces (iv) develop customized robotization for collaboration with workers at construction sites.

### Planned presentation and action

Implementation of the ACon 4.0-project takes place in three work packages with underlying "tasks". There is a pronounced organization that ensures that deliveries and results are obtained.

- WP 1. Value chains & Business models - develop a traditional and new disruptive business model linked to small-scale robot production.
- WP 2. Technology development - digital information structure, building system, robot, rules and sensor technology
- WP 3. Communication & dissemination to Swedish construction industry and international collaboration - Initiate a construction robot lab at LTH with several stakeholders in academia and national construction industry, and there is also a dedicated international collaboration with the German INKOBÄU-project (<https://construction-robotics.de/>)

## THE SURGEON'S PERSPECTIVE

**Researchers: Charlotta Johnsson, Anders Robertsson and Martin Karlsson in collaboration with colleagues at Linköping University, Skånes universitetssjukhus, Business Region Skåne, Cognibotics, and others.**

**Funding: Vinnova**



Today's surgical reports consists of a written textual presentation which only the surgeon and the corresponding core-team can understand. One goal is to improve tomorrow's surgical reports by replacing it with a film with 3D-images in high resolution. In this way, the report will be more complete and understandable for a larger audience. In addition, they can serve as a learning platform useful for e.g. students in medicine, and practicing surgeons preparing for a similar operation. Robotics is needed when collecting the film material and 3D-images, in order to track the precise perspective of the surgeon. Our vision is to provide the hospitals with modern surgical reports, which also facilitates for improved learning in surgical operations and healthcare.

The live surgical field, as the surgeon visually perceives it, contains invaluable image information needed for surgical training, clinical consultations and support the development of surgical robots. However, access to the surgeon's view of the reality is highly restricted because there are

currently no technical solutions to collect, reproduce, and share this 3-D image information. At the present, only the surgeon can see the organs and pathologies that need surgical attention.

The goal of this project is to develop technical solutions to collect image data during open heart surgery, and to reproduce 3-D heart models that can be used for education, clinical consultations, and in the future advance the development of autonomous robotic systems. The overall goal is to achieve increased safety and quality in surgical care.

Components that will be developed:

- A camera system for collection of 3-D video images.
- A platform for interactive visualisation of the surgical field.
- A database that within 3 years will collect data from 5000-10000 surgical cases, for use in machine learning algorithms, augmented reality, and, ultimately robotic surgery.

## SEMANTIC MAPPING AND VISUAL NAVIGATION FOR SMART ROBOTS

**Researchers:** Marcus Greiff, Bo Bernhardsson, Anders Robertsson and Zhiyong Sun with colleagues from the Depts of Mathematics, Lund, and Chalmers University of Technology.

**Funding:** SSF

Why is it that today's autonomous systems for visual inference tasks are often restricted to a narrow set of scene types and controlled lab settings? Examining the best performing perceptual systems reveals that each inference task is solved with a specialized methodology. For instance, object recognition and 3D scene reconstruction, despite being strongly connected problems, are treated independently and an integrated theory is lacking. We believe that in order to reach further, it is necessary to develop smart systems that are capable of integrating the different aspects of vision in a collaborative manner. We gather expertise from computer vision, machine learning, automatic control and optimization with the ambitious goal of establishing such an integrated framework.

The research is structured into four work packages:

- Scene modelling
- Visual recognition
- Visual navigation
- System integration to achieve a perceptual robotic system for exploration and learning in unknown environments.

As a demonstrator, we will construct an autonomous system for visual inspection of a supermarket using small-scale, low-cost quadcopters. The system goes well beyond the current state-of-the-art and will provide a complete solution for semantic mapping and visual navigation. The basic research outcomes are relevant to a wide range of industrial applications including self-driving cars, unmanned surface vehicles, street-view modelling and flexible inspection in general.

## AUTONOMOUS FLIGHT (LUAV@LUND)

**Researchers:** Rolf Johansson, Marcus Greiff, Anders Robertsson and Zhiyong Sun in cooperation with partners at 17 other departments at Lund University

**Funding:** Lund University cooperation grant *The future of drones*

The project aims at strengthening the capacity within Lund University to address the societal needs by establishing an interdisciplinary platform for the development and application of autonomous drone systems for a variety of societal sectors. Within the platform, the aim is to connect and tie together established technology development (e.g., robotics, AI, image processing), research application (e.g., remote sensing and the study of cultural heritage) and applications in different societal sectors (e.g., forestry, agriculture, energy, construction, rescue opera-

tions) to make them inform of each other in a collaborative learning environment and create new synergies. We also aim to incorporate and integrate user views and perspectives to enable the development of knowledge and innovation directed towards private companies as well as the public sector. The project is expected to result in an increased network of collaborating partners, interdisciplinary grants for research and demonstrable applications for autonomous drone operations in the selected areas.

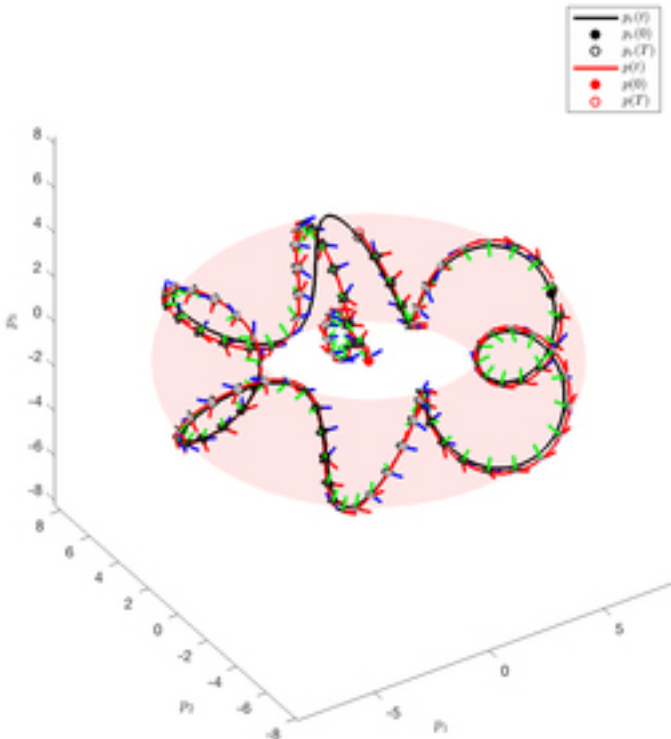

## CONTROL OF THE EUROPEAN SPALLATION SOURCE

**Researchers:** Bo Bernhardsson, Anders J Johansson (Dept. of Electrical and Information Technology), Rolf Johansson, Olof Troeng, Björn Olofsson

**Funding:** European Spallation Source, ESS



The European Spallation Source will be a major user facility at which researchers from academia and industry will investigate scientific questions using neutron beams.

Neutron methods provide insights about the molecular building blocks of matter not available by other means. Applications include research in life science, soft condensed matter physics, chemistry of materials, fundamental particle physics and engineering materials.

### **The need of cavity field control**

The protons will be accelerated by oscillating electromagnetic fields confined in metal structures called RF cavities. In total there will be 155 RF cavities of six different types along the more than 400 meters long linear accelerator. In terms of average power, the ESS accelerator will be the

world's most powerful.

To properly accelerate the protons it is crucial to accurately control the amplitudes of the electromagnetic fields, as well as their phases relative to the protons. Otherwise, the protons get the wrong velocity, and get deflected into the cavity walls, causing radioactivation.

### **Cavity Field Control**

To control the cavity fields, feedback loops with sampling frequencies of 10 MHz will be used. The Department of Automatic Control is involved in system modeling and controller design for these loops, as well as supporting the requirement engineering for RF system components. The work is coordinated by this group at the Department of Electrical and Information Technology.



Our analysis of the field-control loop has been based on an equivalent complex-valued baseband representation of the system dynamics. This representation is well known, but it has not previously been used for control design.

With the complex-valued representation, the cavity dynamics takes the form of a single-input single-output system, which greatly simplifies the analysis.

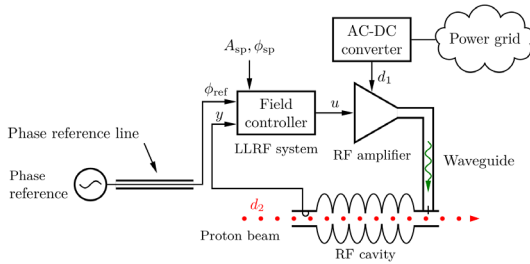

Schematic of the field-control loop at ESS.

Bode magnitude diagram for the 6-cell, ESS medium-beta cavity. Note that parasitic resonances only occur at negative frequencies, manifesting the complex-coefficient nature of the system.

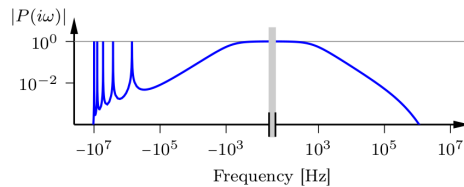

### Temperature Control of Phase-Reference Line

In order to distribute the reference phase from the master oscillator to the beam position monitors and the 155 cavity field control loops with sufficiently small drift requires that the more than 500 meters long phase distribution line is temperature stabilized to less than a tenth of a degree.

The Dept. of Automatic Control at Lund University is involved in the design and development of the temperature control system for the phase distribution line. The research performed includes modeling and simulation of the control system as well as experimental evaluations on a prototype of the phase-reference distribution system.

### Compensation of Lorenz-Force Detuning

The high strengths of the electro-magnetic fields in the super conducting cavities leads to mechanical deformation cavity wall, which changes

their fundamental resonance frequency. This leads to reduced efficiency and makes the RF field control problem harder. The Department of Automatic Control will together with collaborating European universities design the control algorithm for the piezo-electric compensation system that will be used to counter-act the Lorenz force detuning. The work is coordinated by this group at the Department of Electrical and Information Technology.

## OTHER INVESTIGATIONS

### Simulations of Cryogenic Distribution Line at ESS

The cryogenic system at ESS has been modeled in Dymola. Simulations have been made of the cool-down and warm-up of the superconducting section of the linear accelerator. Also the required capacity of the helium safety discharge system has been investigated.

## CLOSED-LOOP COMBUSTION CONTROL

**Researchers:** Rolf Johansson in cooperation the Division of Combustion Engines, Lund University

**Funding:** Competence Center Combustion Processes (KCFP)

A fourth term of has now been granted Competence Center of Combustion Processes (KCFP) for the time interval 2018-2021 with a budget of 30MSEK per year. Previous KCFP program terms covered the years 2006-2009, 2010-2013 and 2014-2017.

KCFP focuses on research of combustion processes between HCCI (Homogeneous Charge Compression Ignition) and classical Otto and Diesel engines.

Project aims:

- Reducing emissions, improving efficiency and repeatability of HCCI and partially premixed combustion (PPC) using closed-loop control;
- Control-oriented modeling and simulation of combustion processes;
- Model-based control and optimization evaluated on test beds.

During the project phase from 2014 to 2017, research has been focused on implementing PPC in a multi-cylinder heavy-duty engine with the objective of advancing the concept from manual operation in steady state towards autonomous and transient operation. Controllers have been designed to regulate ignition delay and pressure-rise rate and to improve low-load operation. The ignition delay determines the degree of premixed combustion and is essential for successful PPC operation. Premixed combustion can give rise to violent combustion and high pressure-rise rates. This can be avoided with the use of small pilot fuel injections. Pilot-injection adjustment with feedback control was used to keep the pressure-rise rate below specified levels. It has also been found that pilot injections are necessary for improvement of charge ignitability at low

engine load where PPC traditionally have had difficulties to operate with sufficient reliability. The designed controllers have been evaluated experimentally in the engine laboratory at Lund University.

During 2017, model predictive control has been used to efficiently fulfill constraints on cylinder pressure, NO<sub>x</sub> emissions and exhaust temperature with multiple injections. It has been shown that multiple injections can be used to increase efficiency with 2 to 4 % if restrictive constraints are imposed. The principle of this control method is to utilize a linearized cylinder pressure model and a novel heat-release detection method, in order to predict how cylinder pressure and NO<sub>x</sub> emissions vary with fuel-injection timings, see Fig.1.

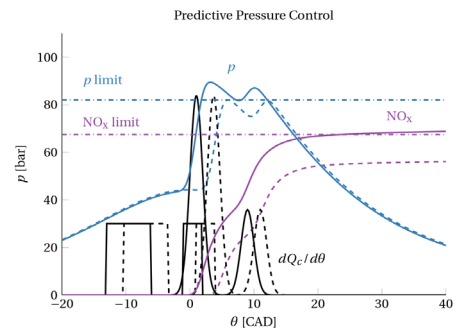

Model predictive control has been utilized to efficiently fulfill constraints on cylinder pressure and NO<sub>x</sub> emissions with the use of multiple injections. This figure illustrates how the controller predicts a deviation in pressure, NO<sub>x</sub> formation and heat release rate (dashed) from the previous cycle data (solid).

## DECENTRALIZED CONTROL STRUCTURES FOR PROCESS CONTROL

**Researcher:** Tore Hägglund

**Funding:** Vinnova

This project aims to revise, improve, and develop new basic control structures for decentralized control used in the regulatory control layer in process control. However, the ideas to be investigated in this project are relevant in other application areas as well.

### Low-order Feedforward Controllers

In this project, the goal is to improve both structures and design methods for feedforward control from load disturbances.

In a first phase, new simple tuning rules for feedforward compensators have been derived. The design objective is to minimize IAE without getting any overshoot in step load disturbance responses. This work has been done in collaboration with University of Almeria. This collaboration continues, and University of Brescia has also been involved in the project where e.g. performance indices for feedforward control have been developed.

Using a structure that decouples feedback and feedforward action, optimal design rules that minimize ISE has been developed. The used structure simplifies tuning of the feedforward controller by allowing the controller to be tuned with respect to the open-loop system while maintaining its properties and performance when used in a closed-loop setting. The structure also enables independent re-tuning of both the feedback and the feedforward controller. Work has also been done concerning characterization of optimal low-order feedforward controllers and practical considerations for implementation.

PID controllers is often implemented with set-point weighting to improve the response to changes in the reference. By using convex optimization techniques the parameters for the set-point weights can be found efficiently, fast as well as be guaranteed to be globally optimal. By solving an optimization problem to find the

optimal set-point weights for a large batch of processes, tuning rules have been found that minimizes IAE. The same optimization framework and formulations can also be used to tune feedforward controllers from measurable disturbances.

### Ratio Control

In ratio control, the control objective is to keep the ratio between two signals, normally flow measurements, at a desired value in spite of variations in the setpoints, load disturbances, and possible control signal saturations. It is also desirable to keep the ratio also in situations when one of the controllers is switched to local setpoint or manual control. Ratio control is a very common problem in process control. It is estimated that about 15% of all controllers in a process control plant are used for ratio control.

The industry standard today is to use either a parallel ratio station or a series ratio station. These methods can only handle a few of the disturbances mentioned above.

In the project we have derived a new method, the Tracking Ratio Station, that handles all disturbances. It has been field tested in a paper mill and is able to track the ratio during setpoint changes, load disturbances in both loops, saturations in both loops, and also the situation when one of the controllers is switched to local setpoint or manual control.

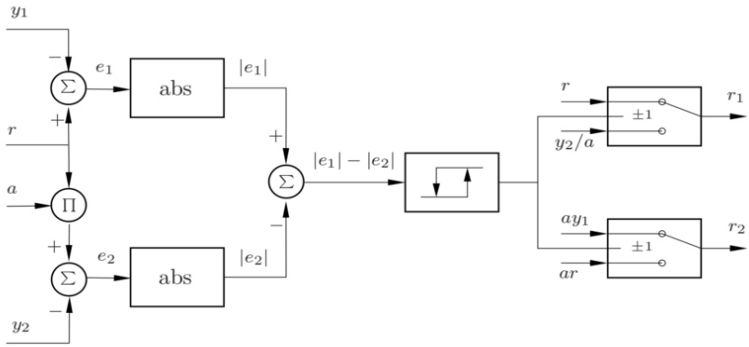

**Feedforward Mid-Ranging Control**

Mid-ranging control is a control strategy that is used when there are more than one manipulated variable available to control a process variable. Mid-ranging control handles the redundancy by coordinating the roles of the different manipulated variables. The most common approach is to introduce valve position controllers (VPC) that control the steady-state position of manipulated variables. There are, unfortunately, some severe

drawbacks with the VPC approach that makes it unsuitable for many industrial applications.

In this project a new approach to mid-ranging control is investigated. The new strategy uses feedforward control to obtain desired steady-state values of the manipulated variables. The approach avoids the drawbacks associated with the VPC approach. The project is sponsored by PiiA-Vinnova and is performed in collaboration with ABB.

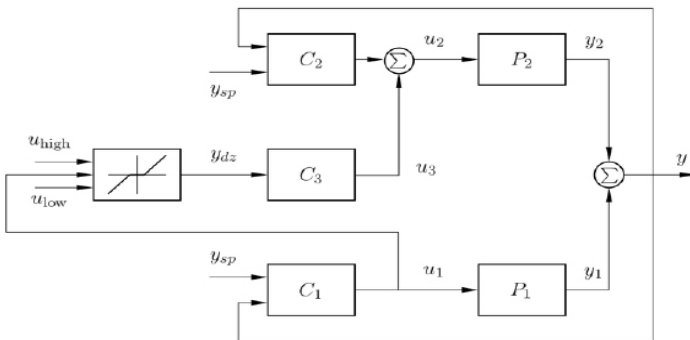

## ANESTHESIA IN CLOSED LOOP

**Reseachers: Kristian Soltesz, Anton Cervin, Olof Troeng and Fredrik Bagge Carlson in collaboration with University of British Columbia**

Computer controlled, or automatic, drug delivery is the process of administering a therapeutic regime to a patient with computer assistance for calculation of optimal dose and delivery schedules. Computer control can improve drug therapy by reducing drug usage and costs, by permitting health care staff to work more efficiently and to provide better standard of care, by allowing the safe use of drugs that are difficult to administer, and by compensation for human failings with computer strengths, such as unlimited attention span and patience, and capacity for quick, accurate and redundant calculation. Our goal is to develop an automatic control system for anesthesia and to demonstrate its efficacy, safety and benefits in an operating room. Although closed-loop anesthesia has previously been proposed and tested, it has yet to have a significant impact on clinical practice. Recent developments in sensing for anesthesia have opened new possibilities for closing the loop. Our research will focus on the deployment of new sensors optimized for controlled drug delivery, robust control

methodology and extensive clinical validation. Clinical partner in the project is the Department of Anesthesia at the British Columbia Children's Hospital (BCCH), Vancouver, Canada, where patient modeling data is collected and clinical trials of the control system are conducted.

During 2018, we have hosted a PhD student from Spain, who has collaborated with local PhD students and department faculty, to compare simple and optimal controllers for closed-loop drug delivery. The conclusion of this work is in the presence of inter-patient variability and model parameter uncertainties stemming from high signal-to-noise ratio and lack of excitation in available identification data, there is little to gain on using more advanced strategies. A journal manuscript is in preparation.

We have also authored and submitted a journal manuscript with the UBC group. In this paper, we disclose and discuss the approach and methodology that was used in the development and clinical evaluation of the closed-loop controlled anesthesia delivery system.

## INDUSTRIAL CLOUD SANDBOX

**Reseachers: Charlotta Johnsson and Johan Eker in collaboration with Ericsson Research and Umeå University**

**Funding: Vinnova**



Industrial Cloud Sandbox (ICS) is a national cloud environment for Swedish industry and academia, enabling collaboration around research and innovation in AI, IoT and industrial applications.

The vision of the environment is to provide knowledge and cloud resources supporting the digitalization of Swedish industry.

## HEMODYNAMIC STABILIZATION

**Researchers: Kristian Soltesz, Henry Pigot, Ylva Wahlquist, Christopher Sturk and Trygve Sjöberg, Audrius Paskevicius (Heart and Lund transplantation), in collaboration with Igelösa Life Science**

### **Funding: Vinnova and VR**

Intensive care patients often rely on a combination of drug, fluid, and other therapies to achieve and maintain stable hemodynamics. This project investigates how pharmacology, mathematical modeling, signal processing and closed-loop control can be combined to control hemodynamic entities such as blood pressure, heart rate, and vascular resistance, as well as related entities such as diuresis. The research relies on close inter-disciplinary collaboration between medical and control systems researchers. It is conducted in a systems engineering framework and comprises the development of both methods and dedicated equipment for clinical verification.

The aim of the project is to develop methods for hemodynamic stabilization of intensive care patients. It comprises closed-loop control of readily measurable signals, including heart rate, arterial and venous blood pressure. Furthermore, the project aims at optimizing hemodynamic parameters, which are not directly measurable, such as cardiac output and responsiveness to volume expansion.

The aim of the project is to develop a generic platform for closed-loop intravenous drug delivery. Apart from being used in research, such a platform can be adapted to a multitude of medical treatment scenarios, foremost in intensive care, where it has the potential to increase the availability of specialized physicians.

The aim of the project is to provide physicians with an 'auto pilot' for hemodynamic stabilization and optimization. The initially considered patient group are heart-beating braindead

patients under intensive care (potential organ donors). Due to the complete loss of vasomotor center function, hormonal and fluid therapy is required to establish hemodynamic stability within this group.

We combine automatic control methods with medical insight, to develop closed-loop controlled therapies. Developed methods are implemented on our in-house developed control system comprising sensors for invasive blood pressure measurement, and urination rate, as well as syringe and volumetric infusion, pumps for closed-loop controlled intravenous drug and fluid administration.

The methods are pre-clinically evaluated in collaboration with the project partner Igelösa Life Science AB.

In 2019, Henry Pigot joined the team as PhD student. His project is strongly related to the above project, but with *ex vivo* heart evaluation as application scenario. Henry and other collaborators are currently developing a research setup enabling the evaluation of hearts *ex vivo*, with the purpose of classifying whether they are suitable for transplantation. The same setup will also be a valuable tool in basic physiology and pharmacology research, in conjunction with the aforementioned closed-loop drug delivery system.



Research setup for ex vivo evaluation and hemodynamic stabilization of heart. The setup relies on soft sensors for state estimation and feedback control for robust performance

## ON HUMANS FOR HUMANS

**Researchers: Charlotta Johnsson in collaboration with Skånes universitetssjukhus, Vävnadsbanken, Cognibotics, and Robovision BVBA**

### **Funding: Vinnova**

By continuous development of new technology for surgical methods our healthcare is improved. Our vision of the project "On Humans for Humans" is to build a new testbed for groundbreaking robotics surgery, consisting of an operating theater with a nearby preparation and

control room. The testbed will be located close to Vävnadsbanken in Lund, which is the largest tissue bank in Scandinavia. Novel methods in collaborative robotics will be evaluated and could eventually, after careful testing, be scaled up and reach the development regions of the world.

## VENTILATOR FOR IMPROVED CARDIOPULMONARY RESUSCITATION

**Researchers: Kristian Soltesz, Henry Pigot, and Trygve Sjöberg, Audrius Paskevicius (Toracic surgery - Heart and Lung transplantation), in collaboration with Igelösa Life Science**

### **Funding: Vinnova**

Sudden cardiac arrest is the second most common cause of death in Sweden, following tumors. Annually, 10 000 persons are subject to sudden cardiac arrest outside of hospitals in the country. In 2015, 585 persons survived through resuscitation, which is the highest number since the 1992 establishment of the Swedish cardiopulmonary resuscitation registry.

Following cardiac arrest, blood circulation in the body ceases, and the brain is subject to irreversible damage within minutes. To counteract this, treatment of sudden cardiac arrest consists mainly in mechanical chest compressions - to circulate blood, combined with artificial gas exchange in the lungs - to deliver oxygen and ventilate carbon dioxide.

The clinical need addressed by this project is to improve survival statistics associated with sudden cardiac arrest. Pre-clinical pilots have demonstrated that it is possible to achieve improved circulation, combined with an increased

coronary perfusion pressure when the gas flow to the patient's lungs is automatically controlled based on the phase of the chest compression cycle. We have developed this idea into a research prototype of a mobile ventilator, specifically intended to be used in cardiopulmonary resuscitation.

The objective of this project is to investigate the efficiency of the new method through randomized pre-clinical studies and to further develop our research prototype. The long-term project goal is to achieve a decrease in deaths caused by sudden cardiac arrest.

In 2018, the results from a porcine study comparing our novel ventilation method to the state of the art were compiled into a manuscript, which has been submitted to Elsevier Resuscitation (a revised version has recently been submitted, following reviewer feedback). There are ongoing plans to incorporate the method into a commercial product and to initiate a human study.

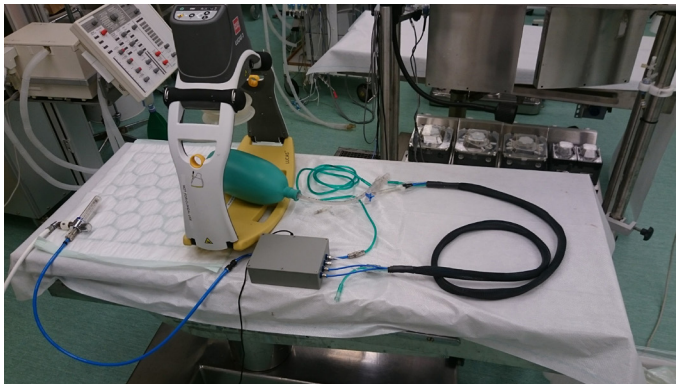

Our ventilator research prototype (gray box with tubing) together with the commercially available LUCAS chest compression device, developed at Igelösa.



## STRATEGIES AND STANDARDS FOR SMART SWEDISH INDUSTRY

**Researchers: Charlotta Johnsson, in collaboration with Blue Institute, SIS, SEK PiiA and Production2030**



**Funding: Vinnova**

Initiatives related to industrial digitalisation are ongoing around the globe. Also for Sweden, digitalisation and the concept of Smart industry is of importance. The Swedish government has selected “Connected Industry and New materials (also called Smart Industry)” as one of five cooperation programs. The vision is to apply new advanced technology to industrial production, with expected outcome of e.g. custom made individual products, and increased transparency (sustainability and work-ethics) of how each product was made.

In order to make this happen, collaboration in two forms, is needed. First, between the technical applications involved in the value-chains that the product is related to (design to product, raw material to product and reuse, etc). This requires international standards that the technical solutions can be based on. Second, collaboration between people, at national and international level, in order to develop these standards. This project aims at igniting the Swedish engagement, and enable Swedish industry

related research results to become international standards. The project aims at intertwining, on one hand the Swedish industry related research related to Smart industry, and on the other hand the Swedish standardisation organisations with their channels to the international arena. This is an example of novelty and hands on activities that have not been done before.

This requires involvement from the Swedish SIPs (mainly PiiA and Prod2030), researchers and industry, and the Swedish standardization organizations (SEK and SIS). This collaboration and joint effort is needed in order to generate a Swedish engagement and take an international position as a leading nationality in the area of Smart Manufacturing.

## MIND METHODOLOGY

**Researchers: Charlotta Johnsson, in collaboration with UC Berkeley, CA, USA, and Jyväskylä University Finland**



In a global context, education is seen as a main driving force for social development, and the pen as the best tool for shaping it’s future. This also applies to engineering and STEM education. However, traditional pedagogical approaches in teaching and learning are entered around theory and practice “to know how to do engineering and apply technology”. The mindset part, to “become an engineer and belong in the tech

community” and “to feel how you can create value for society” is often left out. The proposed new pedagogical methodology, called Mind Methodology, includes game-based and student-centred activities related to mindset and personal development of the students. Our vision for this novel methodology is to enhance and broaden traditional engineering and STEM education and, hence, to increase quality in education.

## REAL-TIME INDIVIDUALIZATION OF BRAIN COMPUTER INTERFACES

**Researchers:** Frida Heskebeck, Olle Kjellqvist, Carolina Bergeling, Bo Bernhardsson and Johan Eker in collaboration with Professor Maria Sandsten and Postdoc Rachele Anderson at Mathematical Statistics, LTH, and Professor Mikael Johansson's group at the Department of Psychology, Lund University

**Funding:** WASP

Controlling the physical world with our mind only opens up for a vast number of exciting opportunities. This can be made possible through so called Brain Computer Interfaces (BCIs). In this project, we primarily focus on BCIs based on ElectroEncephaloGram (EEG) measurements, collected through the use of an EEG-cap. Although the technology behind BCIs have improved steadily over recent years, there is still much to be done. We investigate what the possibilities and limitations of BCIs are in terms of efficiency, reliability and individualizability together with our collaborators at the

Department of Mathematical Statistics and the Department of Psychology at Lund University (see above for more details). Bringing together cross-disciplinary expertise, we have identified several critical obstacles that prevent BCIs from becoming a truly life-changing technology, and methods to overcome them. We see several important areas of use such as communication and control for severely motor-impaired users, smart hearing aids, gaming-devices and forensics tools, as well as different health-related applications, such as rehabilitation, including restoration of motor control after stroke.

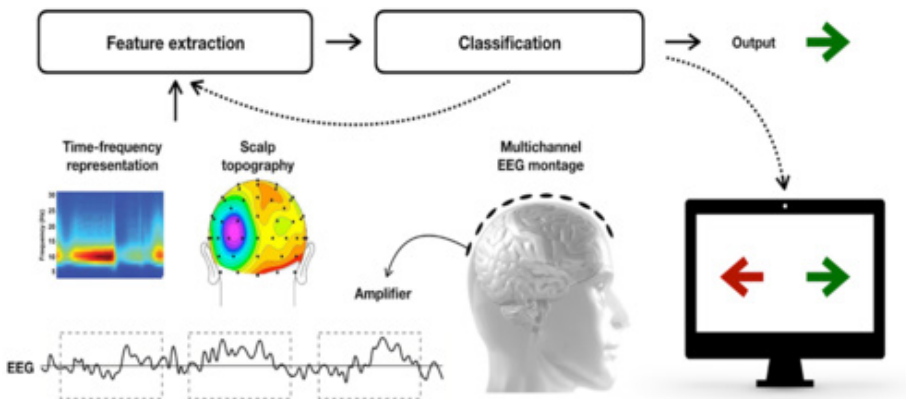

Our approach: Closed-loop design of the BCI with state-of-the-art time-frequency decomposition and feature extraction based on cognitive modeling.

## TOOLS AND SOFTWARE

- Julia packages
- JGrafchart
- Jitterbug: A Matlab toolbox for real-time control performance analysis
- JITTERTIME: Real-time control performance simulation
- TrueTime: Simulation of Networked and Embedded Control Systems

### JULIA PACKAGES

Researchers at the department, in particular Fredrik Bagge Carlson and Mattias Fält, have contributed to several registered packages for the Julia programming language:

- ControlSystems.jl – A control systems toolbox for Julia. (Several add-on packages are available.)
- BasisFunctionExpansions.jl – Basis function expansions for Julia.
- DeterministicPolicyGradient.jl – Reinforcement learning with deterministic policy gradient methods.
- DifferentialDynamicProgramming.jl – A package for solving differential dynamic

programming and trajectory optimization problems.

- DynamicMovementPrimitives.jl – Learning dynamic movement primitives in Julia.
- LPVSpectral.jl - A toolbox for least-squares spectral estimation and (sparse) LPV spectral decomposition.
- SingularSpectrumAnalysis.jl – A package for performing singular spectrum analysis.
- CholmodSolve2.jl – Package for solving linear systems given an LDLt factorization.
- FirstOrderSolvers.jl – Large scale convex optimization solvers in Julia.

### JGRAFCHART

Grafchart is a language for supervisory level sequence control and procedure handling that has been developed at the department since 1991. Grafchart is based on ideas from Grafcet/Sequential Function Charts, Petri nets, Statecharts, and object-oriented programming.

The original implementation of Grafchart had the same name and was developed in G2 from Gensym Corporation. Using this platform

Grafchart was used for batch recipe control, diagnosis of mode-changing processes, alarm filtering, implementation of operator decision support systems, and implementation of robot cells. In 2001 an open implementation of Grafchart was made in Java. It is called JGrafchart and is used in our laboratory exercises on logical sequence control and batch control as well as in several research projects.

### **JITTERBUG: A MATLAB TOOLBOX FOR REAL-TIME CONTROL PERFORMANCE ANALYSIS**

Jitterbug is a MATLAB-based toolbox that allows the computation of a quadratic performance criterion for a linear control system under various timing conditions. Using the toolbox, one can easily and quickly assert how sensitive a control system is to delay, jitter, lost samples, etc., without resorting to simulation. The tool is quite general and can also be used to investigate jitter-compensating controllers, a periodic

controllers, and multi-rate controllers. As an additional feature, it is also possible to compute the spectral density of the signals in the control system. The main contribution of the toolbox, which is built on well-known theory (LQG theory and jump linear systems), is to make it easy to apply this type of stochastic analysis to a wide range of problems.

### **JITTIME: REAL-TIME CONTROL PERFORMANCE SIMULATION**

JitterTime is a spin-off from the Matlab toolbox Jitterbug and can be used for calculating the performance of a controller under non-ideal timing conditions. Examples of such conditions include delay and jitter due to CPU and network scheduling, lost samples or lost controls due to packet loss or execution overruns, and aperiodic behavior due to clock drift, asynchronous nodes, and random sampling. Both Jitterbug and JitterTime evaluate a quadratic cost function for a mixed continuous-time/discrete-time linear system driven by white noise. The main difference is

the timing model. In Jitterbug, the timing of the discrete systems are governed by random delays with specified probability density functions. This allows the total system to be treated as a jump-linear system, and covariance can be calculated by solving a set of linear equations. In JitterTime, however, the timing is arbitrary and completely driven by the user. This allows for more complex timing scenarios to be analyzed, including scheduling algorithms with long-term timing dependencies and asynchronous execution in distributed control systems.

### **TRUETIME: SIMULATION OF NETWORKED AND EMBEDDED CONTROL SYSTEMS**

TrueTime is a Matlab/Simulink-based simulator for real-time control systems. Offering Simulink blocks that model real-time kernels and wired/wireless networks, TrueTime facilitates co-simulation of scheduling algorithms, control tasks, network protocols, and continuous plant dynamics.

TrueTime has been developed at the Department of Automatic Control since 1999. It is open source, written in C++, and can easily be extended with new functionality. TrueTime has been used in wide range of research projects and has also found use in university courses and in industry.

## **Publications and seminars**

---

This chapter contains a list of publications and seminars during 2019

## PUBLICATIONS 2019

You can find references to all the publications on [www.control.lth.se/publications](http://www.control.lth.se/publications) and almost all of them can be downloaded from this site. Any of the reports may, however, be borrowed through your library service or from the following libraries in Sweden:

- Göteborgs universitetsbibliotek
- Kungliga Biblioteket
- Linköpings universitetsbibliotek
- Lunds universitetsbibliotek
- Stockholms universitetsbibliotek
- Umeå universitetsbibliotek
- Uppsala universitetsbibliotek

## Publications 2017 - 2019

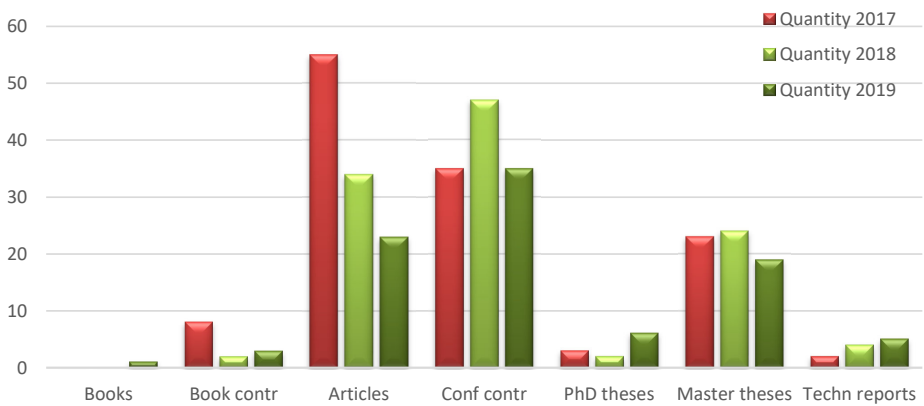

**BOOK**

Hägglund, Tore; *Praktisk processreglering (4 uppl.)* Lund: Studentlitteratur AB, 2019. 210 p.

**BOOK CONTRIBUTION**

Soltész, Kristian; van Heusden, Klaske; Dumont, Guy A.; *Models for control of intravenous anesthesia. Automated drug delivery in anesthesia.* Elsevier, 2019.

Shevtsov, Stepan; Weyns, Danny; Maggio, Martina; *Self-adaptation of software using automatically generated control-theoretical solutions.* In Engineering adaptive software systems : Communications of nii shonan meetings, Springer Nature Singapore, 2019.

Salami, Momoh Jimoh Eyiomika; Johansson, Rolf; Leang, Kam K.; Zou, Qingze; Devasia, Santosh; Nelson Dorn, C.; *Signals and systems.* In Robert H. Bishop (Ed.): Mechatronic System Control, Logic, and Data Acquisition, CRC Press/Balkema, 2019.

**JOURNAL ARTICLES**

Abdelzاهر, Tarek; Hao, Yifan; Jayarajah, Kasthuri; Misra, Archan; Yao, Shuochao; Skarin, Per; Weerakoon, Dulanga; Årzén, Karl-Erik; *Five Challenges in Cloud-Enabled Intelligence and Control.* ACM Transactions on Internet Technology, 2019.

Anistratov, Pavel; Olofsson, Björn; Nielsen, Lars; *Efficient Motion Planning for Autonomous Vehicle Maneuvers Using Duality-Based Decomposition.* IFAC-PapersOnLine, 52:5, pp. 78–84, 2019.

Bimbo, Joao; Turco, Enrico; Ghazaei Ardakani, Mahdi; Pozzi, Maria; Salvietti, Gionata; Bo, Valerio; Malvezzi, Monica; Prattichizzo, Domenico; *Exploiting Robot Hand Compliance and Environmental Constraints for Edge Grasps.* Frontiers in robotics and AI, 6, 2019.

Fors, Victor; Olofsson, Björn; Nielsen, Lars; *Yaw-Moment Control At-the-Limit of Friction Using Individual Front-Wheel Steering and Four-Wheel Braking.* IFAC-PapersOnLine, 52:5, pp. 458–464, 2019.

Ghazaei Ardakani, M. Mahdi; Olofsson, Björn; Robertsson, Anders; Johansson, Rolf; *Model Predictive Control for Real-Time Point-to-Point Trajectory Generation.* In: IEEE Transactions on Automation Science and Engineering. 2019 ; Vol. 16, No. 2. pp. 972-983.

Hägglund, Tore; *The one-third rule for PI controller tuning.* In: Computers and Chemical Engineering. 2019 ; Vol. 127. pp. 25-30.

Jiang, Bomin; Sun, Zhiyong; Anderson, Brian D.O.; Lageman, Christian; *Higher order mobile coverage control with applications to clustering of discrete sets.* In: Automatica. 2019 ; Vol. 102. pp. 27-33.

Jouini, Taouba; Dörfler, Florian; *Parametric local stability condition of a multi-converter system.* In: arXiv preprint arXiv:1904.11288. 2019.

Li, Xiufei; Yin, Lianhao; Tunestål, Per; Johansson, Rolf; *Learning Based Model Predictive Control of Combustion Timing in Multi-Cylinder Partially Premixed Combustion Engine.* SAE Technical Paper, 2019.

Li, Yuling; Zhang, Kai; Liu, Kun; Johansson, Rolf; Yin, Yixin; *Neural-network-based adaptive control for bilateral teleoperation with multiple slaves under Round-Robin scheduling protocol.* In: International Journal of Control. 2019.

Pates, Richard; Mallada, Enrique; *Robust scale-free synthesis for frequency control in power systems.* IEEE Transactions on Control of Network Systems, 6:3, pp. 1174–1184, 2019.

- Rossi, Wilbert Samuel; Como, Giacomo; Fagnani, Fabio; *Threshold Models of Cascades in Large-Scale Networks*. In: IEEE Transactions on Network Science and Engineering. 2019 ; Vol. 6, No. 2. pp. 158-172.
- Scepanovic, Petar; Hodel, Flavia; Mondot, Stanislas; Partula, Valentin; Byrd, Allyson; Hammer, Christian; Alanio, Cécile; Bergstedt, Jacob; Patin, Etienne; Touvier, Mathilde; Lantz, Olivier; Albert, Matthew L.; Duffy, Darragh; Quintana-Murci, Lluís; Fellay, Jacques; *A comprehensive assessment of demographic, environmental, and host genetic associations with gut microbiome diversity in healthy individuals*. Microbiome 2019, Vol. 7, No. 1.
- Shevtsov, Stepan; Weyns, Danny; Maggio, Martina; *SimCA: A control-theoretic approach to handle uncertainty in self-adaptive systems with guarantees*. In: ACM Transactions on Autonomous and Adaptive Systems. 2019 ; Vol. 13, No. 4.
- Soltesz, Kristian; Paskevicius, Audrius; Pigot, Henry; Liao, Qiuming; Sjöberg, Trygve; Steen, Stig; *Phase-controlled intermittent intratracheal insufflation of oxygen during chest compression-active decompression mCPR improves coronary perfusion pressure over continuous insufflation*. In: Resuscitation. 2019 ; Vol. 138. pp. 215.
- Sun, Zhiyong; Yu, Changbin Brad; *Dimensional-invariance principles in coupled dynamical systems: A unified analysis and applications*. In: IEEE Transactions on Automatic Control. 2019 ; Vol. 64, No. 8. pp. 3514-3520.
- Sun, Zhiyong; Sugie, Toshiharu; *Identification of Hessian matrix in distributed gradient-based multi-agent coordination control systems*. Numerical Algebra, Control and Optimization, 9:3, pp. 297-318, 2019.
- van Heusden, Klaske; Soltesz, Kristian; Cooke, Erin; Brodie, Sonia; West, Nicholas; Ansermino, J. Mark; Dumont, Guy A.; *Optimizing robust PID control of propofol anesthesia for children; design and clinical evaluation*. In: IEEE Transactions on Biomedical Engineering. 2019 ; Vol. 66, No. 10. pp. 2918-2923.
- Wang, Liliang; Sun, Zhiyong; Cao, Yue; *Adaptive synchronization of complex networks with general distributed update laws for coupling weights*. In: Journal of the Franklin Institute. 2019.
- Xu, Tao; Duan, Zhisheng; Sun, Zhiyong; *Event-based distributed robust synchronization control for multiple Euler-Lagrange systems without relative velocity measurements*. In: International Journal of Robust and Nonlinear Control. 2019 ; Vol. 29, No. 11. pp. 3684-3700.
- Yang, Qingkai; Sun, Zhiyong; Cao, Ming; Fang, Hao; Chen, Jie; *Stress-matrix-based formation scaling control*. In: Automatica. 2019; Vol. 101. pp. 120-127.
- Yin, Lianhao; Turesson, Gabriel; Tunestål, Per; Johansson, Rolf; *Evaluation and transient control of an advanced multi-cylinder engine based on partially premixed combustion*. In: Applied Energy. 2019 ; Vol. 233-234. pp. 1015-1026.
- Yin, Lianhao; Turesson, Gabriel; Johansson, Rolf; Tunestål, Per; *Nonlinear estimation of variables for heat release calculation using a gradient method*. In: Journal of Dynamic Systems, Measurement and Control, Transactions of the ASME. 2019; Vol. 141, No. 6.

## CONFERENCE CONTRIBUTIONS

- Barzegaran, Mohammadreza; Cervin, Anton; Pop, Paul; *Towards quality-of-control-aware scheduling of industrial applications on fog computing platforms*. IoT-Fog 2019 - Proceedings of the 2019 Workshop on Fog Computing and the IoT. editor / Gowri Sankar Ramachandran; Jorge Ortiz. Association for Computing Machinery, Inc, 2019. pp. 1-5.



- Brandenburg, Björn; Maggio, Martina; Yun, Heechul; *Message from the Chairs*. RTAS 2019. 2019 IEEE Real-Time and Embedded Technology and Applications Symposium (RTAS). Vol. 2019-April IEEE - Institute of Electrical and Electronics Engineers Inc., 2019. pp. ix-x (Proceedings of the IEEE Real-Time and Embedded Technology and Applications Symposium, RTAS).
- Cao, Yue; Sun, Zhiyong; Anderson, Brian D.O.; Sugie, Toshiharu; *Almost global convergence for distance- and area-constrained hierarchical formations without reflection*. The 15th IEEE International Conference on Control and Automation. 2019.
- Cervin, Anton; Pazzaglia, Paolo; Barzegaran, Mohammadreza; Mahfouzi, Rouhollah; *Using JitterTime to Analyze Transient Performance in Adaptive and Reconfigurable Control Systems*. 2019 24th IEEE International Conference on Emerging Technologies and Factory Automation (ETFA). IEEE - Institute of Electrical and Electronics Engineers Inc., 2019. pp. 1025-1032.
- Fält, Mattias; Giselsson, Pontus; *QPDA: Dual Active Set Solver for Mixed Constraint Quadratic Programming*. In 58th IEEE Conference on Decision and Control, CDC 2019, Nice, France, December 2019.
- Fred-Ojala, Alexander; Sidhu, Ikhtlaq; Johnsson, Charlotta; Suoranta, Mari; *The Berkeley Innovation Index: A Quantitative Approach to Measure, Track and Forecast Innovation Capability Within Individuals and Organizations*. Mobile and Wireless Technology 2018 - International Conference on Mobile and Wireless Technology ICMWT 2018. Springer, 2019. pp. 311-320 (Lecture Notes in Electrical Engineering).
- Greiff, Marcus; Sun, Zhiyong; Robertsson, Anders; Johansson, Rolf; *Temporal viability regulation for control affine systems with applications to mobile vehicle coordination under time-varying motion constraints*. The 2019 European Control Conference. Institute of Electrical and Electronics Engineers Inc., 2019.
- Greiff, Marcus; Robertsson, Anders; Berntorp, Karl; *Performance Bounds in Positioning with the VIVE Lighthouse System*. In 22th International Conference on Information Fusion (FUSION), Ottawa, Canada, July 2019.
- Grussler, Christian; Giselsson, Pontus; *Optimality interpretations for atomic norms*. 2019 18th European Control Conference, ECC 2019. Institute of Electrical and Electronics Engineers Inc., 2019. pp. 1473-1477.
- Jouini, Taouba; Dorfler, Florian; *Local Synchronization of Two DC/AC Converters Via Matching Control*. Paper presented at 18th European Control Conference, ECC 2019, Naples, Italy.
- Liu, Ji; Pare, Philip E.; Du, Erhu; Sun, Zhiyong; *A Networked SIS Disease Dynamics Model with a Waterborne Pathogen*. The 2019 American Control Conference. 2019. pp. 2735-2740.
- Maggistro, Rosario; Como, Giacomo; *Stability and optimality of multi-scale transportation networks with distributed dynamic tolls*. 2018 IEEE Conference on Decision and Control, CDC 2018. Vol. 2018-December Institute of Electrical and Electronics Engineers Inc., 2019. pp. 211-216.
- Mandrioli, Claudio; Leva, Alberto; Bernhardsson, Bo; Maggio, Martina; *Modeling of energy consumption in GPS receivers for power aware localization systems*. ICCPS 2019 - Proceedings of the 2019 ACM/IEEE International Conference on Cyber-Physical Systems. editor / Gowri Sankar Ramachandran; Jorge Ortiz. Association for Computing Machinery, Inc, 2019. pp. 217-226.
- Mandrioli, Claudio; Maggio, Martina; *Towards testing self-adaptive software for cyber-physical systems*. 2 p.
- Millnert, Victor; Eker, Johan; Bini, Enrico; *End-to-end deadlines over dynamic topologies*. 31st Euromicro Conference on Real-Time Systems: ECRTS 2019. editor / Sophie Quinton. Vol. 133 Schloss Dagstuhl - Leibniz-Zentrum für Informatik, 2019. pp. 10:1–10:22 (Leibniz International Proceedings in Informatics (LIPIcs)).

- Millnert, Victor; Eker, Johan; Bini, Enrico; *Achieving predictable and low end-to-end latency for a network of smart services*. 2018 IEEE Global Communications Conference (GLOBECOM). 2019.
- Nayak Seetanadi, Gautham; Årzén, Karl-Erik; Maggio, Martina; *Model Checking a Self-Adaptive Camera Network with Physical Disturbances*. IEEE International Conference on Autonomic Computing. IEEE - Institute of Electrical and Electronics Engineers Inc., 2019. pp. 95-104.
- Orlov, Yury; Rantzer, Anders; Aguilar, Luis T.; *Adaptive H-infinity Synthesis for Linear Systems with Uncertain Parameters*. 2018 IEEE Conference on Decision and Control (CDC). Institute of Electrical and Electronics Engineers Inc., 2019. pp. 5512-5517.
- Pates, Richard; Yamamoto, Kaoru; *Sensitivity Function Trade-Offs for Networks with a String Topology*. 2018 IEEE Conference on Decision and Control, CDC 2018. Institute of Electrical and Electronics Engineers Inc., 2019. pp. 5869-5873.
- Pazzaglia, Paolo; Mandrioli, Claudio; Maggio, Martina; Cervin, Anton; *DMAC: Deadline-Miss-Aware Control*. 31st Euromicro Conference on Real-Time Systems: ECRTS 2019. editor / Sophie Quinton. Vol. 133 Schloss Dagstuhl - Leibniz-Zentrum für Informatik, 2019. pp. 1:1-1:24 (Leibniz International Proceedings in Informatics (LIPIcs)).
- Rantzer, Anders; Valcher, Maria Elena; *A Tutorial on Positive Systems and Large Scale Control*. Proceedings IEEE Conference on Decision and Control. Institute of Electrical and Electronics Engineers Inc., 2019. pp. 3686-3697.
- Rantzer, Anders; *Realizability and internal model control on networks*. 2019 18th European Control Conference, ECC 2019. Institute of Electrical and Electronics Engineers Inc., 2019. pp. 3475-3477.
- Ruuskanen, Johan; Peng, Haorui; Martins, Alexandre; *Latency prediction in 5G for control with deadline compensation*. IoT-Fog '19 Proceedings of the Workshop on Fog Computing and the IoT . ACM, NY, USA, 2019. pp. 51-55.
- Ruuskanen, Johan; Cervin, Anton; *Event-Based State Estimation Using the Auxiliary Particle Filter*. 2019 European Control Conference (ECC). IEEE Press, 2019.
- Schulze Darup, Moritz; Book, Gerrit; Giselsson, Pontus; *Towards real-time ADMM for linear MPC*. 2019 18th European Control Conference, ECC 2019. Institute of Electrical and Electronics Engineers Inc., 2019. pp. 4276-4282.
- Skarin, Per; Årzén, Karl-Erik; Eker, Johan; Kihl, Maria; *Cloud-Assisted Model Predictive Control*. In 2019 IEEE International Conference on Edge Computing : (EDGE), 2019.
- Stålberg, Rasmus; Nilsson, Gustav; Como, Giacomo; *On Robustness of Equilibria in Dynamical Transportation Networks*. 2019 18th European Control Conference (ECC). IEEE - Institute of Electrical and Electronics Engineers Inc., 2019. pp. 2209-2214.
- Sugie, Toshiharu; Anderson, Brian D.O.; Sun, Zhiyong; Dong, Huichao; *On a hierarchical control strategy for multi-agent formation without reflection*. 2018 IEEE Conference on Decision and Control, CDC 2018. Institute of Electrical and Electronics Engineers Inc., 2019. pp. 2023-2028.
- Sun, Zhiyong; Greiff, Marcus; Robertsson, Anders; Johansson, Rolf; *Feasible coordination of multiple homogeneous or heterogeneous mobile vehicles with various constraints*. The 2019 International Conference on Robotics and Automation (ICRA) . Institute of Electrical and Electronics Engineers Inc., 2019. pp. 1008-1013.
- Thelander Andrén, Marcus; *Using Radial Basis Functions to Approximate the LQG-Optimal Event-Based Sampling Policy*. 2019 18th European Control Conference (ECC). Institute of Electrical and Electronics Engineers Inc., 2019.
- Troeng, Olof; Falt, Mattias; *A Seemingly Polynomial-Time Algorithm for Optimal Curve Fitting by Segmented Straight Lines*. 2018 IEEE Conference on Decision and Control, CDC 2018. Vol. 2018-December Institute of Electrical and Electronics Engineers Inc., 2019. pp. 4091-4096.

- Troeng, Olof; Falt, Mattias; *Sparsity-constrained optimization of inputs to second-order systems*. 2019 18th European Control Conference, ECC 2019. Institute of Electrical and Electronics Engineers Inc., 2019. pp. 406-410.
- Visioli, Antonio; Häggglund, Tore; *Inversion-based feedforward actions in a ratio control system*. American Control Conference 2019. Philadelphia, USA, 2019.
- Vreman, Nils; Maggio, Martina; *Multilayer distributed control over 5G networks: Challenges and security threats*. IoT-Fog 2019 - Proceedings of the 2019 Workshop on Fog Computing and the IoT. editor / Gowri Sankar Ramachandran; Jorge Ortiz. Association for Computing Machinery, Inc, 2019. pp. 31-35.
- Vreman, Nils; Pates, Richard; Krueger, Kristin; Fohler, Gerhard; Maggio, Martina; *Minimizing Side-Channel Attack Vulnerability Via Schedule Randomization*. In 2019 IEEE 58th Conference on Decision and Control (CDC), 2019.

### PHD THESES

- Bagge Carlson, Fredrik; *Machine learning and system identification for estimation in physical systems*, PhD Thesis TFRT-1122, Department of Automatic Control, Lund University, Sweden, January 2019.
- Bergeling, Carolina; *On H-infinity Control and Large-Scale Systems*; PhD Thesis TFRT-1125, Department of Automatic Control, Lund University, June 2019.
- Karlsson, Martin; *Human-Robot Interaction Based on Motion and Force Control*; PhD Thesis TFRT-1124, Department of Automatic Control, Lund University, Sweden, April 2019.
- Millnert, Victor; *A Timely Journey Through the Cloud*; PhD Thesis TFRT-1126, Department of Automatic Control, Lund University, Sweden, September 2019.
- Nilsson, Gustav; *On Robust Distributed Control of Transportation Networks*; PhD Thesis TFRT-1123, Department of Automatic Control, Lund University, February 2019.
- Troeng, Olof; *Cavity Field Control for Linear Particle Accelerators*; PhD Thesis TFRT-1127, Department of Automatic Control, Lund University, Sweden, November 2019.

### TECHNICAL REPORTS

- Bagge Carlson, Fredrik; *Optimization of Controller Parameters in Julia using ControlSystems.jl and Automatic Differentiation*, Technical reports TFRT-7656, Department of Automatic Control, Faculty of Engineering LTH, Lund University, 2019. 11 p.
- Bagge Carlson, Fredrik; *Parallel computing in Julia*, Technical reports TFRT-7657 : Case study from Department of Automatic Control, Faculty of Engineering LTH, Lund University, 2019. 7 p.
- Cervin, Anton (Editor); Rasmusson, Monika (Editor); *Activity Report 2018 Annual Reports TFRT-4046*, Department of Automatic Control, Lund Institute of Technology, Lund University, 2019.
- Cervin, Anton; *JitterTime 1.0—Reference Manual*, Technical Reports TFRT-7658, Department of Automatic Control, Faculty of Engineering LTH, Lund University, 2019. 20 p.
- Cervin, Anton (Editor); Maggio, Martina (Editor); Soltesz, Kristian (Editor); *Projects in Automatic Control 2018*, Technical Reports TFRT-7659, Department of Automatic Control, Lund Institute of Technology, Lund University, 2019.

**MASTER THESES**

- Abramsson, Andreas; *Collision Avoidance in Low-Speed Maneuvering using Camera Data*. Master's Thesis TFRT-6078, Supervisors: Lazic, Nenad (external) and Johansson, Rolf; Robertsson, Anders; Department of Automatic Control, Lund University, Sweden, June 2019.
- Agner, Felix; *Creating Electrical Load Profiles Through Time Series Clustering*. Master's Thesis TFRT-6092, Supervisors: Engström, Daniel (external) and Grönqvist, Johan; Rantzer, Anders; Department of Automatic Control, Lund University, Sweden, September 2019.
- Andrén, Wilhelm and Hjertberg, Ella; *Gyro Stabilization of a Positioning Unit*. Master's Thesis TFRT-6082, Supervisors: Niklasson, Torkel (external) and Robertsson, Anders; Årzén, Karl-Erik; Department of Automatic Control, Lund University, Sweden, June 2019.
- Artursson, Mathias; *Dual-Motor Control for Backlash Reduction in Parallel-Kinematic Robot Joints*. Master's Thesis TFRT-6086, Supervisors: Sörnmo, Olof (external) and Johansson, Rolf; Robertsson, Anders; Department of Automatic Control, Lund University, Sweden, September 2019.
- Babiera Sancho, Carlos; *Modelling of respiratory mechanics during cardiopulmonary resuscitation*. Master's Thesis TFRT-6077, Supervisors: Pigot, Henry; Soltesz, Kristian; Häggglund, Tore; Department of Automatic Control, Lund University, Sweden, June 2019.
- Christiansson, Martin; *Reinforcement Learning – Intelligent Weighting of Monte Carlo and Temporal Differences*. Master's Thesis TFRT-6072, Supervisors: Bagge Carlson, Fredrik; Robertsson, Anders; Department of Automatic Control, Lund University, Sweden, June 2019.
- Elm, Sebastian; *Cascade Matched Filtering & Adaptive Threshold Techniques on Optical Tracking Signals under AWGN*. Master's Thesis TFRT-6076, Supervisors: Winter, Andreas (external) and Johansson, Rolf; Årzén, Karl-Erik; Department of Automatic Control, Lund University, Sweden, June 2019.
- Grahovic, Mia and Rosicki, Madeleine; *Development and Evaluation of a Torque-Vectoring Algorithm on RWD Racing Cars using a Dual Clutch*. Master's Thesis TFRT-6081, Supervisors: Kempe, Mariann (external) and Olofsson, Björn; Johansson, Rolf; Department of Automatic Control, Lund University, Sweden, August 2019.
- Green, Sebastian and Månsson, Pontus; *Autonomous control of unmanned aerial multi-agent networks in confined spaces*. Master's Thesis TFRT-6084, Supervisors: Yngve, Simon (external) and Sun, Zhiyong; Robertsson, Anders; Johansson, Rolf; Department of Automatic Control, Lund University, Sweden, August 2019.
- Homssi, Rebeca; *Intelligent Swing Doors - Reducing Air Infiltration Using Smarter Sensors*. Master's Thesis TFRT-6091, Supervisors: Dreyer, Roger (external) and Cervin, Anton; Årzén, Karl-Erik; Department of Automatic Control, Lund University, Sweden, August 2019.
- Johansson, Daniel; *Dynamic path planning for collision avoidance in a robotized framework for autonomous driving verification*. Master's Thesis TFRT-6087, Supervisors: Molina Acosta, Angel (external) and Rantzer, Anders; Robertsson, Anders; Department of Automatic Control, Lund University, Sweden, August 2019.
- Knutsen, Sverre; *Gaussian processes for online system identification and control of a quadrotor*. Master's Thesis TFRT-6085, Supervisors: Greiff, Marcus; Robertsson, Anders; Johansson, Rolf; Department of Automatic Control, Lund University, Sweden, August 2019.
- Lundholm, Axel; *Accelerate Business Value in Manufacturing with Advanced Analytics*. Master's Thesis TFRT-6089, Supervisors: Chauca, David (external) and Johansson, Charlotta; Robertsson, Anders; Department of Automatic Control, Lund University, Sweden, August 2019.

- Norborg Persson, Nicklas and Josefsson, Per; *Power peak reduction and control of automatic sliding doors*. Master's Thesis TFRT-6090, Supervisors: Dreyer, Roger (external) and Cervin, Anton; Årzén, Karl-Erik; Department of Automatic Control, Lund University, Sweden, December 2019.
- Persson, Angelica and Lundberg, Pontus; *Optimization of Reverse Osmosis Performance*. Master's Thesis TFRT-6073, Supervisors: Sendelius, Peter (external) and Soltesz, Kristian; Hägglund, Tore; Department of Automatic Control, Lund University, Sweden, August 2019.
- Söderberg, Erik; *Object detection and avoidance using LiDAR on a hydrofoil boat*. Master's Thesis TFRT-6074, Supervisors: Sloth Lauszus, Krisitian (external) and Robertsson, Anders; Årzén, Karl-Erik; Department of Automatic Control, Lund University, Sweden, June 2019.
- Sondell, Gustav; *Improved control strategies for primary frequency control in Swedish combined heat and power plants*. Master's Thesis TFRT-6079, Supervisors: Granberg, Henrik (external) and Hägglund, Tore; Soltesz, Kristian; Department of Automatic Control, Lund University, Sweden, June 2019.
- Tamilinas, Tomas and Singh, Chitranjan; *Energy optimization tool for mild hybrid vehicles with thermal constraints*. Master's Thesis TFRT-6083, Supervisors: Pourabdollah, Mitra (external) and Giselson, Pontus; Bernhardsson, Bo; Department of Automatic Control, Lund University, Sweden, August 2019.
- Wahlquist, Ylva; *Individualized closed-loop anesthesia through patient model partitioning*. Master's Thesis TFRT-6080, Supervisors: Soltesz, Kristian; Johansson, Rolf; Department of Automatic Control, Lund University, Sweden, June 2019.

## SEMINARS AT THE DEPARTMENT

### January

- 10 *Decision Support Systems for Insulin Therapy in Type 1 Diabetes*, Marzia Cescon, Harvard University.
- 16 *Lyapunov stability: Why uniform results are important, and how to obtain them*, Erjen Lefeber, Eindhoven University of Technology.
- 17 *Knowledge and Wavelet Analysis Techniques in System Identification*, Professor Natalia N. Bakhtadze, V.A. Trapeznikov Institute of Control Sciences, Moscow, Russia.
- 17 *Explainable AI - How to make artificial agents interpreting and interpretable*, Hedvig Kjellström, KTH in Stockholm.
- 18 Defense of Doctoral Dissertation: *Machine Learning and System Identification for Estimation in Physical Systems*, Fredrik Bagge Carlson, Department of Automatic Control, Lund University.
- 24 *Swarm robotics: recent results and new research directions*, Marco Dorigo.

### February

- 04 *Clockless Synchronization for Cooperating Agents*, Luis Almeida, Electrical and Computer Engineering Department of the University of Porto (UP).
- 13 Master's Thesis Presentation: *Vision based collision avoidance during low speed maneuvering*, Andreas Abramsson.
- 14 *Input-and-state observability of structured systems*, Federica Garin, NeCS team at INRIA and GIPSA-lab, Grenoble (France).
- 14 *Efficient finite abstraction of dynamical systems for formally correct control*, Samuel Coogan, Georgia Tech.
- 14 *Decentralized and reinforcement learning approaches to congestion control*, Neil Walton, University of Manchester.
- 15 Defense of Doctoral Dissertation: *On Robust Distributed Control of Transportation Networks*, Gustav Nilsson, Department of Automatic Control, Lund University.
- 19 *Social Media Signal Processing: A Noisy Channel Approach*, Professor Tarek Abdelzaher, Department of Computer Science, the University of Illinois at Urbana Champaign.
- 19 *Deep Learning for IoT Systems*, Professor Tarek Abdelzaher, Department of Computer Science, the University of Illinois at Urbana Champaign.
- 22 *Robust stability analysis of PDEs using Lyapunov functionals and LMIs*, Anton Selivanov, KTH, Stockholm.

### March

- 06 *How to accelerate convex optimisation with machine learning*, Sebastian Banert, KTH Royal Institute of Technology.
- 28 *Shape and motion control of multi-robot formations under inconsistent measurements*, Hector Garcia de Marina, University of Southern Denmark.

### April

- 09 *A data consistency approach to model validation*, Andreas Lindholm, Uppsala Universitet.
- 23 Master's Thesis Presentation: *Improved control strategies for primary frequency control in Swedish combined heat and power plants*, Gustav Sondell.

- 25 *Latent Optimal Control*, Professor Patrick van der Smagt, Ludwig-Maximilians-Universität, and Volkswagen Group, Munich, Germany.
- 26 Defense of Doctoral Dissertation: *Human-Robot Interaction Based on Motion and Force Control*, Martin Karlsson, Department of Automatic Control, Lund University.

## May

- 02 Master's Thesis Presentation: *Individualized closed-loop anesthesia through patient model partitioning*, Ylva Wahlquist.
- 06 *Current swarm robotics research at IRIDIA*, Marco Dorigo, Université Libre de Bruxelles.
- 09 *Planar Sliding Using Friction Patches*, Mahdi Ghazaei, Cognibotics AB.
- 28 Master's Thesis Presentation: *Power Peak Reduction and Control of Automatic Sliding Doors*, Nicklas Norborg Persson.
- 28 Master's Thesis Presentation: *Intelligent Swing Doors: Reducing Air Infiltration Using Smarter Sensors*, Rebeca Homssi.
- 29 *Data-Driven System for learning driver behaviors from IMU data*, Amani Jaafer.

## June

- 03 Master's Thesis Presentation: *Stabilization of positioning unit with IMU sensors*, Ella Hjertberg
- 04 *Wind farm modeling and control for power grid support*, Dennice Gayme, Johns Hopkins University.
- 04 *Decision-making in interconnected multiagent networks: roles of frustration and social commitment*, Claudio Altafini, Linköping University.
- 04 *Induced L2 gain computation for rational LPV systems using Finsler's lemma*, Balázs Adam Kulcsár, Chalmers University of Technology.
- 04 *Input-to-state stability of infinite-dimensional bilinear systems*, Birgit Jacob, University of Wuppertal.
- 05 Defense of Doctoral Dissertation: *On H-infinity Control and Large-Scale Systems*, Carolina Bergeling.
- 07 Master's Thesis Presentation: *Gaussian processes for online system identification and control of quadrotor*, Sverre Knutsen.
- 07 Master's Thesis Presentation: *Development and Evaluation of a Torque-Vectoring Algorithm on RWD Racing Car using a Dual Clutch*, Mia Grahovic and Madeleine Rosicki.
- 12 Master's Thesis Presentation: *Autonomous control and position referencing of unmanned aerial vehicles in confined spaces*, Sebastian Green and Pontus Månsson.
- 12 Master's Thesis Presentation: *Energy optimization tool for mild hybrid vehicles with thermal constraints*, Tomas TAMILINAS and Chitranjan Singh.
- 13 Master's Thesis Presentation: *Dynamic path planning for collision avoidance in a robotized framework for autonomous driving verification*, Daniel Johansson.
- 13 Master's Thesis Presentation: *Accelerate Business Value with Advanced Analytics*, Axel Lundholm
- 14 Master's Thesis Presentation: *Dual Motor Control for Reduction of Backlash in Parallel-Kinematic Robot Joints*, Mathias Artursson.

## August

- 27 Master's Thesis Presentation: *Creating Electrical Load Profiles Through Time Series Clustering*, Felix Agner.

## September

- 11 *Schedule Adaptation in the Presence of Uncertainties*, Enrico Bini, Politecnico di Torino.
- 12 *Feedback control goes wireless: Guaranteed stability over low-power multi-hop networks*, Marco Zimmerling, TU Dresden, Germany.
- 13 Defence of Doctoral Dissertation: *A Timely Journey Through the Cloud*, Victor Millnert.

## October

- 01 *Data-driven control in the frequency-domain: from the choice of the specifications to controller validation*, Pauline Kergus, ONERA, Toulouse, France.
- 01 *Controllability of Networked Systems Based on Structural Features of Underlying Graphs*, Shima Sadat Mousavi, ETH Zürich.
- 09 Master's Thesis Presentation: *Configuration and control of the Laser-Tau robot system for high accuracy laser applications*, Álvaro Torregrosa Antón, Lund University.
- 14 *More Mathematics Mandatory in Data Science*, Prof. Dr. Bart De Moor, KU Leuven.
- 14 *Frequency Control in the Nordic System*, Daniel Karlsson, DNV GL.
- 23 Bachelor's Thesis Presentation: *Cascaded Deep Neural Networks In Embedded Systems*, Fredrik Annerstedt, LTH.
- 28 *Probabilistic machine-learning for identification of linear systems with an application in finance*, Martin Tegner, Oxford Univeristy, UK.

## November

- 08 Master's Thesis Presentation: *Reverse osmosis temperature control*, Dennis Dalenius, LTH.
- 12 *Target Localization and Circumnavigation using Bearing Measurements*, Dr Mohammad Deghat, UNSW.
- 20 *Highlighting scale fragilities in network systems*, Emma Tegling, MIT.
- 27 *Motion planning and control of automated road vehicles in critical situations*, Lars Svensson, Automatic Control, KTH.
- 29 Defence of Doctoral Dissertation: *Cavity Field Control for Linear Particle Accelerators*, Olof Troeng.

## December

- 03 *Determining Causality*, Brian Anderson, Australian National University.
- 05 *Beyond consensus and polarisation: complex social phenomena in social networks*, Brian Anderson, Australian National University.
- 13 Master's Thesis Presentation: *Road Friction Estimation Using an Artificial Neural Network in a Simulated Environment*, Jonas Karlsson, Lund University.
- 17 *Adaptive optimization and control in online advertising*, Niklas Karlsson, Verizon Media.
- 18 *Estimation, Learning, and Control of Autonomous Systems*, Karl Berntorp, Mitsubishi Electric Research Laboratories.
- 19 Master's Thesis Presentation: *Dynamic Capacity Networks in Embedded Systems*, George Ryrstedt, LTH.
- 19 Master's Thesis Presentation: *Sensorless method of detecting plunger position in solenoid actuators*, Axel Knutsson and Simon Hed, Lund University.



# External Contacts

---

External contacts of importance to our projects, both academic and industrial

Together with external contacts and partners the goal is to solve real control problems. A mix of fundamental and applied work is a cornerstone of our activities. In these kind of projects the problems are approached with an open mind without glancing at particular methods. One purpose is to learn about real problems, another is to learn about new problems that are suitable for theoretical research. An important role for universities is to organize knowledge in such a way that the results can easily be digested by engineers in industry.

### **Lund / Academia**

Lund University, Dept Clinical Sciences Lund, Biomedical Engineering, Lund  
 Lund University, Dept of Chemical Engineering, Lund  
 Lund University, Dept of Computer Science, Sweden.  
 Lund University, Dept of Mathematics, LTH, Lund  
 Lund University, Dept of Electrical and Information Technology, Lund  
 Lund University, Div. Combustion Engines, Department of Heat and Power Engineering, Lund  
 Lund University and Skåne University Hospital, Dept. Cardiothoracic Surgery, Lund  
 Skåne University Hospital, Medical Services, Lund

### **Lund / Industry & Society**

Axis Communications AB  
 Business Region Skåne  
 Cognibotics, Lund  
 Combine Systems, Lund  
 Ericsson, Lund  
 European Spallation Source (ESS)  
 Igelösa Life Science AB  
 Max IV, Lund  
 Vänadsbanken

### **Sweden / Academia**

Chalmers University of Technology  
 KTH - Royal Institute of Technology  
 Linköping University  
 Luleå University of Technology  
 Umeå University  
 Uppsala University  
 Örebro University

### **Sweden / Industry & Society**

5 High Innovations  
 ABB, Sweden  
 ABB Corporate Research, Västerås, Sweden  
 ABB Automation, Malmö  
 Assa Abloy, Landskrona  
 Blue Institute, Sweden  
 BorgWarner, Landskrona

Clarister  
Comsys  
Corebon, Sweden  
Gustaf Fagerberg AB, Sweden  
Inventor  
IUC Syd - Industriellt utvecklingscentrum Syd  
OP5  
Perstorp AB, Sweden  
PiiA  
Prod2030  
RISE  
Saab AB, Linköping, Sweden  
Saab Bofors Dynamics, Linköping, Sweden  
Saab Kockums, Sweden  
Scania, Södertälje  
Schneider Electric  
Sectra Imtec  
Sekvensa AB  
SEK/IEC  
SESAM-Sverige  
Siemens  
SIS/ISO  
Swedish Energy Agency  
Swedish Modules  
Swegon Operations

**Nordic countries / Academia**

Aalto University, Finland  
DTU - Technical University of Denmark  
Jyväskylä University, Finland. Mari Suoranta  
NordForsk - Nordic University of Hubs  
NTNU - Norwegian University of Science and Technology, Dept of Engineering Cybernetics

**Nordic countries / Industry & Society**

Granlund OY  
kW-set OY  
Orbis OY  
UR, Denmark

**Europe / Academia**

ETH Zürich, Switzerland.  
European Innovation Academy, EU. Collaboration with Anni Sinijärvi.  
Graz University of Technology - Institute of Computer Graphics and Vision, Austria  
KU Leuven, Belgium  
Lübeck University, Germany  
Oxford University, UK

Max Planck Institute for Software Systems, Germany  
 Politecnico di Milano, Italy  
 Politecnico di Torino, Italy  
 Sant'Anna School of Advance studies, Realt-Time Systems Labs, Pisa, Italy  
 Technion - Israel Institute of Technology, Haifa  
 Tel Aviv Univeristy; Israel  
 TU Chemnitz - Robotics and Human-Machine-Interaction Lab  
 TU Darmstadt, Germany  
 TU Delft, Netherlands  
 TU Eindhoven, Netherlands  
 TU Kaiserslautern, Germany  
 TU Munich, Germany  
 UNED, Spain  
 Universidad de Almeria, Spain  
 Universidad La Laguna, Spain  
 Universidad Nacional de San Juan, Spain  
 Università Luigi Bocconi, Milan, Italy  
 University Groningen, Belgium  
 University of Brescia, Italy  
 University of Cyprus, KIOS Research and Innovation Center of Excellence, Cyprus  
 University of Cambridge, UK  
 University of Ghent, Belgium  
 University of Modena, Italy  
 University of Rome Tor Vergata, Rome, Italy  
 University of Salerno - Dept of Industrial Engineering, Italy

### **Europe / Industry & Society**

AICo Software, Austria  
 AlfaEvolution Technology, Italy  
 Bosch Corporate Research, Germany  
 Città dell Salute e della Scienza, Turin, Italy  
 euRobotics  
 Fluxguide, Austria  
 Machine Learning Reply, Italy  
 Robovision BVBA  
 SmartFactory, DFKI, Kaiserslautern, Germany  
 Tecnalia, Spain  
 Telecom Italia

### **World / Academia**

Beihang University, BUA, Beijing, China  
 California Institute of Technology, USA.  
 Caltech, USA  
 Hanyang University, Seoul, Korea  
 Massachusetts Institute of Technology, USA  
 McGill University, Canada

Saint Mary's University, Canada

Sydney University, Australia

Tsinghua University, Dept Precision Instruments and Mechanology, Beijing, China

University of British Columbia (UBC), Vancouver, Canada

University of California, Sutardja Center for Entrepreneurship and Technology, Berkeley, CA, USA

University of Maryland College Park, USA

Zhejiang University, Control Science and Engineering, Hangzhou, China

### **World / Industry & Society**

Lawrence Berkeley National Laboratory, CA, USA

Mariner Partners, Canada

Missing Link Technologies, Canada

Mitsubishi Electric Research Laboratories, Massachusetts, USA

United Technologies, Hartford, USA





# Economy

---

This chapter contains an overall view of the economy and funding

## ECONOMY

The turnover for 2019 was 55 MSEK, a slight decrease compared to 2018. About half of the income comes from Lund University and the remaining half from external grants.

The activities and the number of employees are now in a growing phase since last year. The number of employees is currently 48 persons including part-time positions (43 full-time equivalents). The department participated in one new project funded by the European Union, in Horizon 2020, the European Research Council (ERC), which started during autumn 2019. The Swedish Foundation for Strategic Research (SSF), Swedish Research Council (VR), Knut and Alice Wallenberg Foundation (KAW) and Swedish Government Agency for Innovation Systems (Vinnova) have also provided substantial support of our activities.

The block grants from VR, KAW and some of the SSF projects are long range. Several projects do, however, have shorter duration i.e. three years or less. To match these with the length of a PhD position, normally for 5 years, we have a long-term internal research planning, and we are careful to bid on projects that fit into our research plan. This has proven efficient to match short-term funding, research planning and personnel.



Above: Profit/loss and agency capital development over the last 5 years



## FUNDING

2019 we had the following external grants:

VR – Feedback Computing in Cyber-Physical Systems  
VR – Resilient Control of Dynamical Network Flows  
VR – Control of Monotone Systems and Diffusions  
VR – Large Scale Convex Optimization  
VR – Hemodynamic Modeling and Control  
VR – Event-Based Control and Estimation with Application to Server Systems  
VR - Fundamental mechanisms for scalable control of large networks  
Vinnova – Line Information System Architecture 2 (LISA2)  
Vinnova – Hemodynamic Stabilization  
Vinnova – Bloqqi: An Open Module Source Language in Automation  
Vinnova – Surgeon’s Perspective UDI-2  
Vinnova – Ventilator for Improved Cardiopulmonary Resuscitation  
Vinnova – ISOTC184/SC5 Chair – Swedish Impact  
Vinnova – Strategies and Standards for Smart Swedish Industries, part 2  
Vinnova – Development of New Method for Midranging Control  
Vinnova – ITEA3, AutoDC  
Vinnova – On Humans for Humans: Testbed for New Surgical Methods  
Vinnova – Innovative Agile Construction for Globally Improved Sustainability (ACon4.0)  
Vinnova – Connected Working Site (Uppkopplad byggplats)  
Boverket - Innovative Construction with Flexible Robot-Human Interaction  
SSF – Societal-Scale Cyber-Physical Transport Systems  
SSF – Semantic Mapping and Visual Navigation for Smart Robots  
EU Horizon 2020 – Scalable Control of Interconnected Systems - an ERC project  
KAW – Wallenberg AI, Autonomous Systems and Software Program (WASP)  
eLLIIT – The Linköping–Lund Initiative on IT and Mobile Communication  
SKB – Control of Stirwelding Process for Sealing  
Swedish Energy Agency – Emissions Control for Low Climate Impact (KCFP3)  
NordForsk – Nordic University Hub on Industrial Internet of Things (HI2OT)

Our major sources of funding for the research are currently;

- Lund University faculty funding
- VR – Swedish Research Council
- KAW – Knut and Alice Wallenberg Foundation
- SSF – Swedish Foundation for Strategic Research
- EU - Horizon 2020
- Vinnova – Swedish Government Agency for Innovation Systems

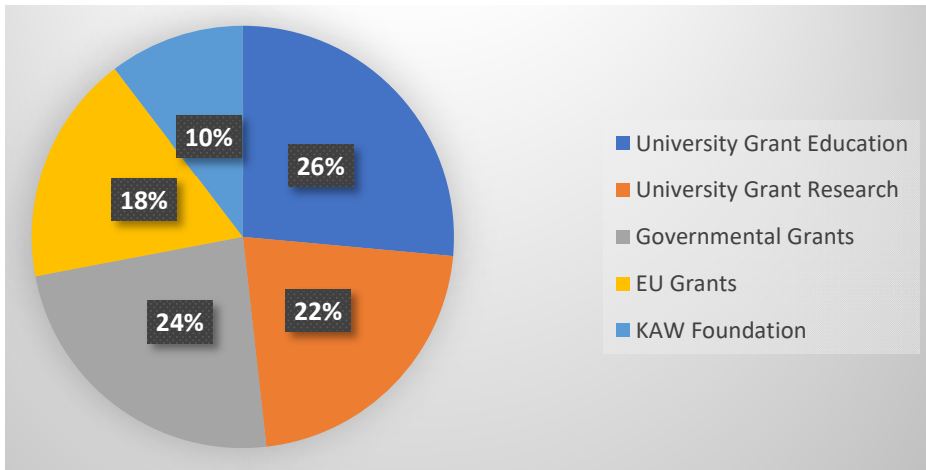

# Staff

---

In this chapter the personnel and their activities are described

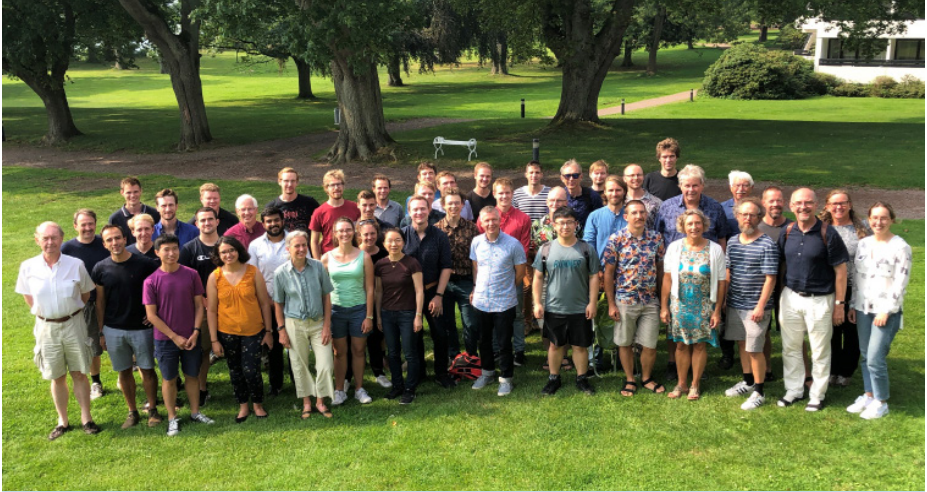

Kick-off at Örenäs slott in August 2019

Personnel per category

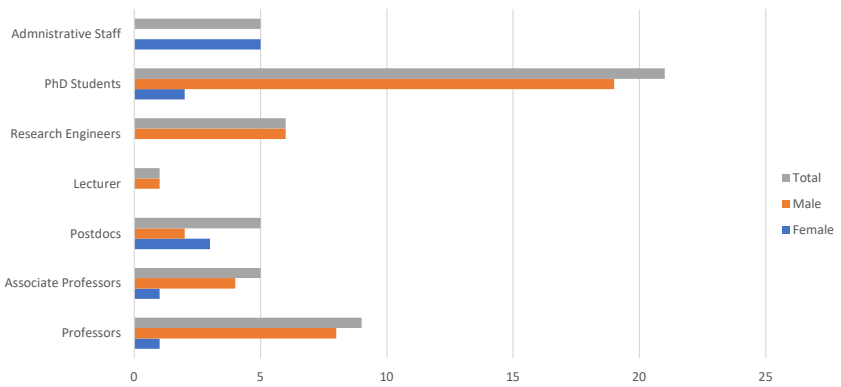

**Professors**

Årzén, Karl-Erik  
 Åström, Karl Johan; senior professor (20%)  
 Bernhardsson, Bo  
 Eker, Johan; adjunct professor (20%)  
 Hagander, Per; professor emeritus  
 Hägglund, Tore, assistant head of department  
 Johansson, Rolf  
 Johnsson, Charlotta  
 Rantzer, Anders; head of department  
 Robertsson, Anders  
 Wittenmark, Björn; professor emeritus

**Associate Professors**

Cervin, Anton; deputy head of department,  
 director of undergraduate studies  
 Como, Giacomo (25%)  
 Giselsson, Pontus; director of graduate studies  
 Maggio, Martina  
 Soltesz, Kristian

**Research engineers**

Andersson, Leif (30%)  
 Andersson, Pontus  
 Blomdell, Anders  
 Korell, Manuel  
 Nilsson, Anders

**Administrators**

Edelborg, Cecilia  
 Nishimura, Mika  
 Rasmusson, Monika (70%)  
 Westin, Eva

**Postdocs**

Banert, Sebastian (from September)  
 Bergeling, Carolina (from July)  
 Sun, Zhiyong  
 Tegling, Emma (from August/MIT)  
 Yetis, Mustafa (from September)

**Researchers/Research assistant**

Olofsson, Björn (20%)  
 Pates, Richard  
 Wahlquist, Ylva

**PhD students**

Bagge Carlsson, Fredrik (until May)  
 Fält, Mattias  
 Greiff, Marcus  
 Grönqvist, Johan (from January)  
 Jouini, Taouba (from August)  
 Heimerson, Albin  
 Heskebeck, Frida (from August)  
 Heyden, Martin  
 Karlsson, Martin (until September)  
 Kjellqvist, Olle (from August)  
 Mandrioli, Claudio  
 Millnert, Victor (until August)  
 Morin, Martin  
 Nayak Seetanadi, Gautham  
 Nilsson, Gustav (until May)  
 Nylander, Tommi  
 Pigot, Henry (from February)  
 Rosdahl, Christian  
 Ruuskanen, Johan  
 Sadeghi, Hamed  
 Salt Ducaju, Julian (from February)  
 Thelander Andrén, Marcus  
 Troeng, Olof  
 Vladu, Emil (from August)  
 Vreman, Nils

**Industrial PhD students**

Martins, Alexandre; Axis  
 Skarin, Per; Ericsson  
 Wingqvist, Birgitta; Kockum (from December)

**DEPARTMENT BOARD**

Anders Rantzer  
 Martina Maggio  
 Giacomo Como  
 Karl-Erik Årzén  
 Anders Nilsson  
 Mattias Fält

**Deputy members**

Anton Cervin  
 Tore Hägglund  
 Bo Bernhardsson  
 Pontus Giselsson  
 Pontus Andersson  
 Martin Morin

## LONG-TERM VISITORS

Bolderman, Max; guest MSc student, TU Eindhoven, The Netherlands (January-March)

Liu, Yang; guest PhD student, Northwest Polytechnical University, China (from August)

Madsen, Emil; guest PhD student, Universal Robotics A/S, Denmark (August-December)

Pazzaglia, Paolo; guest PhD student, Scuola Superiore Sant'Anna, Italy (until March)

Svensson, Lars; guest PhD student, KTH, Sweden (from November)

Wilhelm, Felix; guest MSc student, TU Chemnitz, Germany (January)

## STAFF ACTIVITIES

### Andersson, Leif

MSc, Research Engineer since 1970. Leif started at the department with responsibility for the teaching and research laboratory. After some years he drifted to computer maintenance and became computer manager. He retired formally in 2012, but was immediately rehired on 30%.

A large part of his time the past year has been spent as an internal LaTeX consultant, helping the PhD students to make their theses beautiful, and also helping the staff with general LaTeX problems.

As previous years he has worked a lot with the publication database LUCRIS, and also assisting with transferring the department web pages to the LTH server.

### Andersson, Pontus

MSc, Research Engineer at the department since 2012.

His main work involves development and design of student laboratory equipment. This includes mechanic and electronic design as well as implementation.

This year among other things resulting in new communication boxes for the courses given in China and a new prototype for the Ball and Beam process. He is also supporting student

projects and is involved in various projects in the Robotics Lab.

### Årzén, Karl-Erik

Professor (2000), PhD (1987), joined the department in 1981.

His research interests are real-time and embedded control, real-time systems, cloud control, feedback computing, autonomous systems, and programming languages for control.

Coordinator for the Lund part of WASP (Wallenberg AI, Autonomous Systems and Software Program). Chair of the Program Management Group for WASP. During the year he has primarily been involved with WASP, the VINNOVA/ITEA3 AutoDC project, and the Nordforsk University Network HI2OT.

He is partly or fully involved in the supervision of six PhD students.

### Åström, Karl Johan

Professor in Automatic Control since 1965 and founder of the department, emeritus from 2000, senior professor since 2010.

He worked with Luca Simoni and Antonio Visioli in Brescia to add effects of dwell time in the LuGre friction model, and with Richard Murray at Caltech on the second edition of the book *Feedback Systems*.

In August and September he visited Rodney Bell and Graham Goodwin to work on boiler control of a sugar mill.

### Bagge Carlson, Fredrik

PhD (2019), Lic. Tech. and MSc .

He is interested in machine learning and system identification, in particular within the field of control and applied to physical systems. He defended his PhD thesis in January 2019, titled *Machine Learning and System Identification for Estimation in Physical Systems*.

### Banert, Sebastian

Sebastian obtained his diploma and PhD degrees in mathematics from Chemnitz University of Technology in 2012 and University of Vienna in

2017, respectively. After a postdoc position at KTH, he joined the department in September 2019.

His research interests are algorithms for convex and large-scale optimisation and monotone inclusions in connection with deep learning and inverse problems.

He is working together in the WASP project of Pontus Giselsson and Emil Björnson (Linköping U) on performance estimations for the aforementioned algorithms and their application in wireless communications.

### **Bergeling, Carolina**

PhD (2019) and Lic. Tech. (2016) in Automatic Control, MSc in Engineering Physics (2013), from Lund University. She has been with the Department of Automatic Control since June 2013, where she is currently a Postdoc.

Her research interests include control of large-scale systems and the intersection between machine learning and control theory.

In June 2019 she presented her PhD thesis *On H-infinity Control and Large-Scale Systems*. In July 2019 she started as a Postdoc in the WASP Expedition Project *Realtime Individualization of Brain Computer Interfaces*, run by Professor Bo Bernhardsson.

She is the co-supervisor of PhD student Frida Heskebeck.

Carolina is also part of two working groups on gender equality and diversity.

### **Bernhardsson, Bo**

PhD 1992, Professor since 1999, has also worked at Ericsson during 2001-2010.

During 2019 he worked as one of the organizers of the graduate school in the WASP Autonomous Systems and Software program. He also worked part in a project for the European Spallation Source with the design of the RF system for the proton accelerator, mainly as a supervisor for Olof Troeng who finished his PhD thesis on cavity field control.

During 2019 he taught a PhD course in stochastic control together with Karl Johan

Åström. He also worked with planning the start of a new international masters program in *Machine Learning, Systems and Control*.

He is currently the main supervisor of two and co-supervisor of six PhD students.

### **Blomdell, Anders**

Research Engineer at the department since 1988. Heavily involved in almost all aspects of Robotics research at the department, also responsible for the department network and lab computers for teaching and research.

Lots of work associated to planning and realizing the big shuffle (renovation of the M-building).

### **Cervin, Anton**

Docent (2008), PhD (2003), MSc (1998). Anton joined the department in 1998 and has been employed as an Associate Professor since 2007.

His research interests include event-based and networked control, real-time systems, cloud control, and computer tools for analysis and simulation of controller timing.

He is the main supervisor of three PhD students and leads research projects within event-based control and estimation and co-design of real-time control systems.

During 2019 he was responsible for the advanced-level course in *Multivariable Control* and was also a teacher in *Project in Automatic Control*. He supervised three master's theses and was the examiner of a further two.

His administrative tasks included being deputy head of the department and director of studies for the first- and second-cycle education at the department.

### **Como, Giacomo**

PhD (2008), Docent (2012). He has been with the faculty at the Department of Automatic Control since 2011 and was promoted Associate Professor (universitetslektor) in 2013.

His research interests are in Dynamics, Information, and Control in Networks, with applications to transport, infrastructure, as well as

social and economic systems. He is PI of the VR Project *Resilient Control of Dynamical Flow Networks*.

During 2019, he has served as main supervisor of Gustav Nilsson (until his graduation in February) and as co-supervisor of Martin Heyden. He has also been main supervisor of Laura Arditti, Leonardo Cianfanelli, Martina Vanelli, Costanza Catalano and Stephane Durand and co-supervisor of Luca Damonte, Leonardo Masai, and Lorenzo Zino at Politecnico di Torino.

In Spring 2019, he taught the master level course *Network Dynamics* at Lund University.

In 2019, he supervised three master theses projects.

During 2019, he has partly been on leave at Politecnico di Torino.

### **Edelborg, Cecilia**

Financial Administrator at the department since 2017.

The responsibilities are primarily accounting regarding travel expenses, intermittent employments, reimbursements, invoices and projects. Also, administration of conferences and kick offs, committees and other administrative tasks.

She is also CPR trained as well as Fire protection trained and a member of the Equality group at the department and work with these questions.

Her background is from the Faculty of Law at Lund University.

### **Eker, Johan**

Docent (2010), PhD (1999). Johan is an adjunct Professor and spends one day a week at the department and the remaining time at Ericsson Research.

His main interests are the area of resource management of large scale compute systems and datacenters using control theory and machine learning. In particular his work with mission critical cloud applications such as distributed control systems and virtualized communication infrastructure.

Johan is the main supervisor for Victor

Millnert and Albin Heimerson and the industrial supervisor for Per Skarin. All three are part of the WASP program. He has also been master's thesis supervisor to Alexander Cobleigh.

### **Fält, Mattias**

MSc, PhD student since August 2015.

His main research interest is methods for large-scale convex optimization. The focus has been on studying and improving convergence rates for first-order methods.

He has been a teaching assistant for both *Automatic Control, basic course* and *Control Theory*. He has also been developing and teaching the new course *Optimization for Learning*.

He presented his research at the conferences ICCOPT and CDC, titled *Dual Active Set Solver for Mixed Constraint Convex Quadratic Programming*.

### **Giselsson, Pontus**

Docent (2018), PhD (2012), MSc (2006). Pontus is currently Associate Professor at the Department of Automatic Control. His research interests are in optimization and its wide range of applications.

He is supervising three PhD students and is director of graduate studies at the Department of Automatic Control.

### **Greiff, Marcus**

He is a postgraduate student at the department of automatic control, currently starting his fourth year of studies since earning his MSc degree in 2017.

His main topic of research concerns nonlinear output feedback for drones, but he also works on Bayesian statistics and state estimation more broadly.

He is involved in an SSF-project concerning visual semantic mapping of indoor environments, but also actively working on a project where we map radiation in outdoor environments using drones, and to a lesser with a project concerning the design and control of small autonomous blimps.



In the year of 2019, we published works related to these topics and projects at ICRA, ECC and FUSION, with three additional works accepted for publication in the upcoming year at ACC and IFAC. He has also been on a four month sabbatical during the summer of 2019, working for Mitsubishi Electric Research Laboratories (MERL), which has resulted in additional publications and two patent applications. He is currently consulting for MERL, and will return in the summer 2020 to continue working on topics related to stochastic control.

In addition to this, he has supervised the MSc thesis of Sverre Knutsen, and is currently supervising the MSc theses of Martin Gemborn and Olle Hedbrant, all of which are related to drone control. On the educational side, he taught the course predictive control, supervising many of its projects and actively re-working the laboratory exercises. He took the course stochastic control and linear systems, both given as PhD-course at the department, and also did the mandatory wasp course in the spring on 2019.

Finally, he has set up and given several demos during the year, including LUAV workshops, events at Ljungbyhed (TFHS) and the robotics week of 2019.

### **Grönqvist, Johan**

PhD (Physics) from 2010, LTH and doctoral student, at the department since 2019.

His general control interests are Learning and, Robustness.

He has been a teaching assistant in *Automatic Control, basic course*. He has also been supervising three master theses projects.

### **Heskebeck, Frida**

Frida has a MSc. in engineering Biotechnology (2019) and started as a PhD student at the department in August 2019.

She is part of a project where we improve EEG-based Brain-Computer Interfaces (BCI) with machine learning, control, and cloud computing. A two-year goal is to implement an application that can be used in real-time, in real-life.

Frida was a teaching assistant in the *Automatic control, basic course* for CMN 2019.

### **Hägglund, Tore**

Professor, PhD (1984). He has been at the department since 1978 except for four years when he worked for ABB. He is responsible for two of the basic courses in Automatic Control in the engineering program.

His main research interests include process control, PID control, decentralized control, and monitoring and diagnosis.

His main research activities during the year have been a new simple design method for PI controllers, feedforward control, ratio control, and mid-ranging control. The research projects are presented on his personal web page at [www.control.lth.se/personnel/](http://www.control.lth.se/personnel/).

During the year, he has also completed the fourth edition of the book *Praktisk Processreglering*.

### **Heimerson, Albin**

MSc, PhD student since August 2018.

His supervisor is Johan Eker and his main project will be a collaboration with Ericsson about automated datacenters. His research interests are towards ML/RL, and he is very interested in how to control complex systems with a combination of ML and classic control.

He has been a teaching assistant in the Systems Engineering/Process Control course and also in the Physiological Models and Computation course.

### **Heyden, Martin**

MSc, PhD student since October 2016.

His main research interest is in the interaction between economics and traffic flows. The research is supervised by Anders Rantzer and Richard Pates, and part of the SSF-SoPhy project which is a collaboration with KTH.

During 2019, he has been a TA in *Non Linear Control*(FRTN05). Coursework completed includes *Stochastic Control and Convex Optimisation*.

**Johansson, Rolf**

Professor, MD (1986), PhD (1983). Active at the department since 1979.

Rolf Johansson's research interests are in system identification, robotics and nonlinear systems and automotive control.

He participates and leads the research projects KCFP Control and is project leader on system autonomy in UAV@Lund. He is coordinating director for Robotics Laboratory with cooperation partners from Dept Computer Science and industrial partners. He has industrial cooperation with Scania. He is responsible for the three courses FRTN35 *System Identification*, FRTN15 *Predictive Control*, and FRTF01 *Physiological Models and Computation*.

He has supervised six PhDs, out of which three of them defended their thesis. Rolf has also supervised seven master theses.

**Johnsson, Charlotta**

Professor (2018), PhD (1999).

Her main research interest covers Automation, Control and Operations. However, she is also involved in the research domains of Innovation and Entrepreneurship, Teaching and Learning in Higher Education, as well as Technology Management and Engineering Leadership. She is the Chair of ISO TC184/SC5, hence actively working on standardisation activities for Smart Manufacturing and Industry 4.0.

During the year 2019, Charlotta has been involved in the Engineering course *Process Control*, and she has been a guest lecturer in the course *Automation in Complex Systems* (given by the Department of Biomedical Engineering). She has also been involved in the PhD-courses *Research Methodology*, *Ethics and Innovation* and *Innovation and Value Creation in Research*.

Charlotta was the supervisor for one master thesis project *Accelerate Business Value in Manufacturing with Advanced Analytics*. She has also given invited seminars to industry focusing on Industry 4.0/Smart Manufacturing.

Since 2017, Charlotta is the Vice Dean of

Engineering Faculty with focus on Collaborations and Innovations.

**Karlsson, Martin**

PhD (2019) and MSc.

His research interests are within state estimation, and robot learning and control.

In 2019, he has been working within in the VINNOVA project Surgeon's Perspective, considering robot-assisted surgery. In April he defended his doctoral thesis titled *Human-Robot Interaction Based on Motion and Force Control*

**Kjellqvist, Olle**

MSc, PhD Student since August 2019.

His supervisor is Anders Rantzer and his main research interests relates to adaptive control and brain-computer interfaces.

He has been a TA in *Multivariable Control (FRTN10)* and the *Automatic Control, basic course (FRTF05)*. Completed coursework includes Linear Functional Analysis and Linear Systems.

**Korell, Manuel**

MSc in Management Engineering. Works at Lund University since 2017.

Spends almost all his time on BYGGrobotics a research project, where we try to utilize industrial robots in the building sector.

**Maggio, Martina**

PhD, 2012, Politecnico di Milano and is now Associate Professor and has now been at the department for 8 years (employed January 1st, 2012).

Her research interests: Real-Time Control Systems. She has two main research interests. The first one has been the design of controllers for computing systems. Many components of a computing system can be designed as controllers: memory allocators, schedulers, and similar components. This is true also for distributed infrastructures like cloud computing facilities. The second research interest concerns the implementation of control systems and their

real-time properties. In that respect, she has been working on what happens when a controller designed with given proven characteristics is implemented and runs in a real computing environment, where unpredictable workloads can lead to missing computational deadlines.

She has been a co-lecturer in the course Real-Time Systems (FRTN01).

Most part of 2019 she has been on sabbatical at Bosch and which is a good way to strengthen the collaboration between industry and academia.

### **Mandrioli, Claudio**

Claudio received Bachelor (2015) and Master degree (2017) from Politecnico di Milano, both of them in Automation and Control engineering. At the end of his master he was a visitor at the department and worked on his final thesis. Afterward he has then been employed as a PhD student at the department since January 2018.

He is part of and founded by the WASP research program.

The main focus of his research work in 2019 was on the testing of controlled systems. This with two different directions: one when the system to be controlled is software-based and the other one that includes traditional control systems based on physical devices.

Another part of his work has been in the field of real-time system analysis. Specifically the study of how the real-time implementation of a control system affects its performance and vice versa how controllers can be implemented in a way that is aware of the real time aspects. This has been done in collaboration with Paolo Pazzaglia from the University of Sant'Anna in Pisa.

In 2019 he was involved as teaching assistant in the basic course in automatic control and the Real-Time Systems course.

### **Millnert, Victor**

PhD (2019) and MSc.

In March 2019 he returned after being a visiting researcher at University of California, Berkeley in the USA.

In September, he defended his thesis *A Timely Journey Through the Cloud*.

### **Morin, Martin**

MSc in Engineering Physics. PhD student at the department since 2017.

Research interests are within large scale optimization with current work focusing on variance reduced stochastic first order methods applied to convex problems.

Teaching duties include the development and execution of the new course *Optimization for Learning*.

### **Nayak Seetanadi, Gautham**

MSc in IC design from NTU-TUM. PhD student at the department since January 2016.

Currently research interests include applications of model checking, bandwidth allocation schemes and safe reinforcement learning.

In November 2019, he was involved in teaching of the basic control course at Beihang University in Beijing, China.

Currently he is teaching of Real-Time Systems and planned project supervision in Process Control.

He is also a member of the Jalm board at the department.

### **Nilsson, Anders**

PhD (2006), Research Engineer since 2010.

Spends most of the time looking after the department computers and their software. Also spends some time maintaining and developing the robotics lab.

### **Nilsson, Gustav**

PhD (2019). MSc in Engineering Physics (2013).

His research interests are in the field of control of networks with applications in transportation networks.

He defended his thesis *On Robust Distributed Control of Transportation Networks* in February 2019.

**Nishimura, Mika**

Born in Japan. Administrator at the department since 2014.

She handles the exam results in Ladok. She has contact with the printing office about doctoral thesis and other publications. She is responsible for purchase of office supplies, books and handles Lucat-catalogue system for the employees at the department. She reviews Lucris-research portal, updates LUP-student paper and parts of the web pages and keeps keys in order among other service-oriented tasks.

She also teaches Japanese at Folkuniversitetet in Lund since 2006.

**Nylander, Tommi**

MSc in Engineering Physics. PhD student since January 2016.

He is part of the WASP Autonomous Clouds and Networks research cluster, focusing on control-based resource management.

During the year he has also taken some courses and been a teaching assistant in the System Identification course as well as in the basic control course.

**Olofsson, Björn**

He obtained the MSc in Engineering Physics in 2010 and the PhD in Automatic Control in 2015, both from Lund University, and has been with the department since 2010. He is currently a researcher at the department, with broad research interests in robotics and control for autonomous vehicles.

During the year, he has been involved in a research project within the ELLIIT Strategic Research Area, investigating optimal vehicle maneuvers and methods for autonomous driving in time-critical situations. He has also taken active part in the teaching at the department and was acting as supervisor of a Master Thesis project.

**Pates, Richard**

Richard obtained the M.Eng degree in 2009 and Ph.D degree in 2014, both from the University of

Cambridge. He is currently an Adjunct Lecturer.

His research focus is on control system design for electrical power systems and autonomous vehicles. The vision is to build a modular theory of control system design that can be used to address the requirements of future large-scale interconnected systems.

**Pigot, Henry**

Henry (Harry) joined the department as a Project Assistant in 2018 and became a PhD student in 2019. He has an Electrical Engineering (Biomedical Option) degree from the University of British Columbia in Vancouver.

Harry's main interest is medical technology development. The focus of his thesis is applying control theory to improve the safety and efficacy of a machine for evaluating heart organ function outside of the body. He works together with Kristian Soltesz and researchers at Igelösa Life Science AB.

In 2019, Harry also continued work on a new ventilation method for CPR together with visiting Master's student Carlos B. Sancho.

Harry took courses in real-time systems, multivariable control, and scientific programming in Julia.

He was a teaching assistant in Basic Automatic Control and prepared a new Furuta pendulum process for use in future labs. He is involved in starting a new makerspace on campus that opened in 2019.

**Rantzer, Anders**

Professor of Automatic Control since 1999 and head of department.

Anders Rantzer is the main supervisor for several PhD students and postdocs.

In 2019, he was teaching *FRTN45 Mathematical Modelling, Advanced Course* and *FRTN05 Nonlinear Control and Servo Systems* at the masters level. He has broad interests in modeling, analysis and synthesis of control systems, with particular attention to uncertainty, optimization, scalability and adaptation.

### **Rasmusson, Monika**

She joined the department in August 2011 and as from March 2017, she took over as finance officer and is now responsible for year-end closing, budget, forecast and reporting, both internally within the faculty and externally to sponsors.

As a part of the administrative team, her work includes backup function for her colleagues, editing the yearly Activity Report, among other administrative tasks.

She has a Bachelor's degree in Business administration, Lund University.

### **Robertsson, Anders**

Professor (2012), Associate professor (2007), Docent (2005), Research Associate (May 2003), PhD (1999), Excellent Teaching Practitioner (ETP) in 2007.

His main interests are in nonlinear control, robotics and control of computing systems.

Currently he is working on parallel kinematic robots, sensor-data integration and force control of industrial robots in collaboration with ABB Robotics/ABB CRC. The research has been conducted within the Robotics Lab, Linneaus Centre LCCC, ELLIIT network, and the projects Smart Systems (SSF), The Surgeons Perspective (VINNOVA) and within a couple of recently started projects related to construction robotics (VINNOVA and Boverket).

He has been teaching in the courses on *Applied Robotics (MMKF15)*, *Control Theory (FRTF15)* and *Basic course on Automatic Control (FRTN05)* at Lund and in Beihang, China, and been supervisor for several project groups in mechatronics, electronics and participated in the teacher education at Vattenhallen, LTH. He has guest lectured on robotics at NTNU and co-organized the 1st Lund-Chemnitz-Trondeheim graduate school of Robotics in Lund, August 2019.

He has acted as advisor/co-advisor for (2+5) PhD students and several Master's Thesis projects.

### **Rosdahl, Christian**

MSc in Engineering Physics (Lund University, 2017) and PhD student at the department since September 2017.

He is part of the Wallenberg AI, Autonomous Systems and Software Program (WASP) and works on a project with focus on efficient learning of dynamical systems with Bo Bernhardsson as supervisor.

During the year, Christian has been a teaching assistant in *Predictive Control* as well as *Network Dynamics*. He has also taken courses on reinforcement learning, software engineering and cloud computing, as well as stochastic control.

### **Ruuskanen, Johan**

MSc, PhD student since 2017.

Johan is part of the WASP research program withing the Autonomous Cloud and Networks cluster. He is supervised by Anton Cervin and Karl-Erik Årzén. During the year Johan has been a teaching assistant for the Network Dynamics and Physiological modelling and computation courses.

His research interests includes control and estimation within cloud systems and applications, and event-based estimation where the focus has been during the year.

### **Sadeghi, Hamed**

MSc in Mechanical Engineering from Sharif University in Iran. He is a PhD student at the Automatic Control Department since 2016.

His research interests are in Large-scale Optimization and its application. His research is a part of Large-scale Optimization and Control cluster within WASP-AS.

### **Soltesz, Kristian**

Kristian obtained the degrees of MSc, PhD, and reader (docent) in 2008, 2013 and 2018. Employed at the department since 2016, and senior lecturer since 2019.

His main line of research is within medical control systems for patient state stabilization. This line of research has been financed by The

Swedish Research Council (VR), VINNOVA, and additional non-government funds. He is currently the PI of two externally financed projects: Hemodynamic Stabilization (VR), and Ventilation for Improved Cardiopulmonary Resuscitation (VINNOVA). Kristian's research is conducted in close collaboration with academic as well as corporate medical researchers, and engineering students at different educational levels. He is currently the main supervisor of one PhD student.

During 2019, Kristian has been responsible for teaching two master level courses: *Process Control/Systems Engineering* and *Project in Automatic Control*. He has been the supervisor of two completed MSc thesis projects, and the examiner of one. Kristian has also been involved as supervisor and examiner of BSc thesis projects in Biomedical engineering.

### **Sun, Zhiyong**

Zhiyong received his PhD at the Australian National University (2017). He joined the Department of Automatic Control as a postdoc researcher in June 2018.

His research interests include autonomous robotic systems, multi-agent formation, and the general field of distributed control and networked systems. His recent research focus has been on event-based control for networked systems and distributed adaptive stabilization of complex networks.

In addition he has taught a PhD level course on Linear System Theory, supervised Sebastian Green and Pontus Månsson's master thesis project, and is the co-supervisor for Marcus Greiff.

He terminated his stay in January 2020 for a new position at Eindhoven University of Technology as assistant professor.

### **Thelander Andrén, Marcus**

MSc in Engineering Physics (2015) and a PhD student at the department since August 2015.

His main research interests are stochastic event-based control and estimation.

During 2019 he has done research on numerical methods for computing optimal sampling

policies for event-based control. He has been teaching in the multivariable control course.

### **Tegling, Emma**

PhD in Electrical Engineering, KTH, 2019. Postdoctoral Researcher since August 2019.

Research interest is analysis and control of large-scale network systems.

She was awarded the Swedish Research Council (Vetenskapsrådet) International Postdoc grant for project *Fundamental mechanisms for scalable control of large networks*.

Postdoctoral research is carried out at the Institute for Data, Systems, and Society at Massachusetts Institute of Technology (MIT).

### **Troeng, Olof**

PhD (2019), MSc (2012)

In November he defended his thesis with the title *Cavity Field Control for Linear Particle Accelerators*, which was based on his work on control algorithms for the accelerating electromagnetic fields in the linear accelerator at the European Spallation Source. An interesting aspect in this work was that it demonstrated the usefulness of complex-coefficient linear system.

### **Vladu, Emil**

MSc in Engineering Physics from Lund University. PhD student at the department since August 2019.

His supervisor is Anders Rantzer and his research project mainly concerns control in large-scale dynamic networks.

During the autumn of 2019, he was a TA for the course *Automatic Control, Basic Course* and he also supervised laboratory exercises in the course *Nonlinear Control and Servo Systems*.

### **Vreman, Nils**

MSc, PhD student since August 2018.

His research interests include fault tolerance, robustness, and resilience in real-time control applications.

During 2019 he has researched control system resilience to controller deadline misses. Nils has

been teaching: *Real-time systems*, *Project in Automatic Control*, and *Multivariable Control*.

### **Wahlquist, Ylva**

MSc (2019), LTH.

Project assistant since September 2019 within the project *Hemodynamic stabilization* together with researchers at Igelösa Life Science where she has worked on an automated system for drug delivery to be used within the field of heart transplantations.

Main area of interest is medical technology development.

### **Westin, Eva**

PhD in French linguistics. Administrator at Automatic Control since 2008 and administrative manager from December 2017 for the administrators and research engineers at the department.

She handles the overall responsibility of human resources, guests and conferences. She also handles part of the process for research studies.

Eva is part of the network AI Lund. Also part of the Togetherness group in the M-building.

## **PROMOTING GENDER EQUALITY AND DIVERSITY AT THE DEPARTMENT JÄLM@REGLER**

The working group on gender equality and diversity was formed in early 2014.

Since the start we have arranged some 20 seminars and workshops by invited speakers on different subjects ranging from research to ergonomics, security and how to implement this at our department.

The project *Supervision 2.0* is a good example on how to guide PhD's in their work. The result of this project was presented at the yearly kickoff 2019 by Carolina Bergeling and Pontus Giselsson. We also had a workshop with Anders Ahlberg from *Genombrottet* concerning this subject.

The group has frequent meetings and discuss different angles of this broad area and follow up the formal documents for creating a good equal working environment for all co-workers.

The seminars have made issues on gender equality and diversity a natural talking point during our coffee breaks, which we believe is crucial for improving and tackling upcoming questions in these areas.

We also have a delegate from our department in the JäLM working group at LTH, Cecilia Edelborg.

## **TOGETHERNESS**

Togetherness - a cooperation over department and group boundaries - is an initiative to promote information and discussion on diversity and gender equality among the employees as well as the students of the M-building. The initiative was taken by Carolina Bergeling and Eva Westin from the Department of Automatic Control in 2016 and has now grown to include members from all departments in the M-building. Since 2016 the group has arranged 13 seminars on the above topics.

### Report from visit in Nepal

In the beginning of July 2019, I visited SMD school in Nepal where the year before I said goodbye to students running an electronics and programming club that we started together in 2017. The Himalayan Makers Guild runs weekly hands-on activities that introduce students aged 10-16 to practical technical skills and the engineering design process. Since I left, the club has been driven entirely by the students using lesson plans we developed while I was at the school.

My objective for revisiting the school was two-fold. First, I wanted to evaluate how the club had progressed after one year of independent operation. Discussions with the club leaders and observations of the activities revealed that, despite the challenge of keeping up regular participation during the hectic school year, the club had succeeded in running weekly activities, training new leaders, and adopting a new head of the club who would be responsible for the year to come. Discussions with the leadership group led to some concrete changes such as lengthening the club schedule to allow for more time on each topic and introducing a leaders notebook to help transfer knowledge from year to year.

The second objective of the trip was to share with the students some like-minded projects here at Lund University to help spark

their imagination. In particular, Vattenhallen shares the club's objective of offering hands-on science and technology experiences. Photos of Vattenhallen's current installations helped highlight its interactive learning approach that is similar to what the students aim for in their club activities. I also explained the teacher-training work that Vattenhallen does to help bring such activities into normal classroom environments, in many ways similar to how the club trains its students to become future group leaders.

Beyond Vattenhallen's work, I showed the students two of the projects I'm involved in through the Automatic Control group at LTH: improving CPR with controlled oxygen ventilation, and testing heart organs outside the body to evaluate their viability for use in transplant surgery. The students had previously show much interest in robotics, so I was excited to show them some of the LU Robotics Lab projects, including videos from Martin Karlsson's thesis work on safe robot control.

The club continues to run weekly activities for 40 members with 14 dedicated club leaders, thanks to the hard work of its participants and support from generous individuals and organizations including Vattenhallen and UBC Sustaingineering.

Henry Pigot, co-founder of the Himalayan Makers Guild



The Himalayan Makers Guild club leaders



## AWARDS

### GRANTS

#### Research Grant

Victor Millnert received a grant from Hörjels Foundation, that supports technical research and graduate education, to support his stay as visiting researcher at University of California, Berkeley.

#### Master Thesis awarded Lilla Polhemspriset 2019

Karl Fredrik Eriksson and Richard Bai have been awarded Lilla Polhemspriset 2019 for their Master Thesis *Motion Planning using Positively Invariant Sets on a Small-Scale Autonomous Vehicle*.



Karl Fredrik Eriksson och Richard Bai

## ASSIGNMENTS

### BOARD MEMBER

#### **Årzén, Karl-Erik**

Member of the Board for the eLLIIT strategic research area.

Chair of the Program Management Group for the Wallenberg Autonomous Systems and Software Program (WASP).

Member of Research Board for the Faculty of Engineering, Lund University.

#### **Como, Giacomo**

Board member of the Excellence Project of the Department of Mathematical Sciences, Politecnico di Torino.

#### **Eker, Johan**

Advisory board member for Internet of Things and People Research Center at Malmo University.

#### **Johnsson, Charlotta**

Board member at SESAM-Sverige, a network for industrial automation.

Board member of CIRCLE, Lund University, Sweden.

Board member of EFL (Executive Foundation Lund), Lund, Sweden.

Board member of Innovation Skåne, Sweden.

Board member of IUC Syd (Industriellt utvecklingscentrum Syd), Malmö, Sweden.

Other Board assignments in external companies.

Member of Research Board for the Faculty of Engineering, Lund University.

#### **Rantzer, Anders**

Member of the steering committee for the International Symposium on Mathematical Theory of Networks and Systems.

Member of Editorial Board for the journal Annual Reviews in Control.

Member of Editorial Board for Proceedings of the IEEE.

#### **Westin, Eva**

Board member in AI Lund.

### MEMBER OF INTERNATIONAL PROGRAM COMMITTEE (IPC)

#### **Cervin, Anton**

Member of the scientific and organizing committee of the Modelica Jubilee Symposium on Future Directions of System Modeling and Simulation, Lund, September 30.

#### **Como, Giacomo**

Member of the IPC of the 8th Conference on Complex Networks and their Applications, 2019 (CTA 2019).

Member of the IPC of the 8th IFAC workshop on Distributed Estimation and Control in Networked Systems, 2019 (NeSys'19).

Member of the IPC of the 2019 IEEE Information Theory Workshop (ITW'19), 2019,

Member of the IPC of the 27th Mediterranean Conference on Control and Applications, 2019 (MED'19).

Organizer and Member of the Scientific Committee of the Thematic Semester on "Network Dynamics and Resilience," the Workshop "Network Dynamics in the Social, Economic, and Financial Sciences," and the Workshop "Resilient Control of Infrastructure Networks," Politecnico di Torino, Fall 2019.

### **Hägglund, Tore**

IPC Member, IEEE International Conference on Emerging Technologies and Factory Automation, ETFA'2019, Zaragoza, Spain.

### **Maggio, Martina**

IPC Member of ECRTS 2019.

IPC Member of ECRTS WiP 2019.

IPC Member of CERTS 2019.

IPC Member of ICPE 2020.

IPC Member of NG-RES 2020.

IPC Member of DATE 2020.

### **Rantzer, Anders**

Member of the IPC for L4DC - Conference on Learning for Decision and Control, UC Berkeley, 2020.

### **Soltesz, Kristian**

IPC member of the 27th Mediterranean Control Conference.

## **OPPONENT AND MEMBER OF EXAMINATION COMMITTEE**

### **Årzén, Karl-Erik**

Member of PhD examination committee of Sophie Cerf, Gipsa Lab, Université Grenoble Alpes, May 16.

### **Bernhardsson, Bo**

Deputy member in examination committees for Muris Sarajlic, communication systems, Lund.

Member in examination committees for Markus Eriksson, signal processing, Uppsala.

Deputy member in examination committees for Jonas Lindstrand, electrical engineering, Lund.

### **Como, Giacomo**

Member of the PhD examination committee for Emma Tegling, KTH, January 18.

Member of the PhD examination committee for Erik Steinmetz, Chalmers University, May 28.

**Cervin, Anton**

Deputy member of the PhD examination committee of William Tärneberg, Department of Electrical and Information Technology, LTH, March 29.

Member of the PhD examination committee of Diana Yamalova, Uppsala University, June 14.

Member of the PhD examination committee of Ana Guasque Ortega, Polytechnical University of Valencia, Spain, December 18.

**Maggio, Martina**

Member of PhD committee of Romain Jacob at ETH.

Member of PhD committee of Riccardo Lucchese at Luleå University of Technology.

Member of PhD committee of Stepan Shevtsov, Katholieke Universiteit Leuven.

**Rantzer, Anders**

External examiner of PhD thesis by Yang Zheng at University of Oxford, January 8, 2019.

External examiner for licentiate thesis by Matias Ignacio Müller Riquelme, KTH Stockholm, May 3.

**Robertsson, Anders**

Chairman at PhD thesis defense Victor Millnert, LTH, Lund university, September 13.

Member of evaluation board for SFI, Research Council of Norway, March 13-15.

Member of Examination board, PhD thesis *Monitoring and control of laser beam butt joint welding* by Morgan Nielsen, University West, Trollhättan, Sweden, April 5.

PhD thesis opponent *On Robotic Assembly and Optimization-Based Control of Industrial Manipulators*, by Mathias Hauan Arbo, at NTNU, Trondheim, Norway, April 24.

Faculty opponent/reviewer for Licentiate thesis by Johan Karlsson, Chalmers, Sweden, May 23.

Examination board member (chairman) for PhD thesis in Mathematical Statistics, Lund by Carl Åkerlindh *Simulation and Estimation of Diffusion Processes: Applications in Finance*, September 27.

Deputy member of examination board for Rachele Anderson's PhD defence in Mathematical Statistics, Lund University, October 4.

**Soltesz, Kristian**

Member of examination committee at Department of Biomedical Engineering, Lund University.

**ADVISORY COMMITTEES AND WORKING GROUPS****Årzén, Karl-Erik**

Member of the Norwegian committee on assessment of competence for the title of full professor in IT.

Chair of the Signals and Systems panel, Swedish Research Council (VR).

Elected member of the Royal Swedish Academy of Engineering Sciences (IVA).

**Como, Giacomo**

Chair of the IEEE-CSS Technical Committee on Networks and Communications.

**Edelborg, Cecilia**

Representative for Automatic Control in the Equality working group (JäLM) at the Faculty of Engineering.

**Johansson, Rolf**

Member of IEEE EMBS Technical Committee (TC) for Biomedical Robotics.

Member of Joint EMBS/RAS Advisory Committee on Biorobotics.

Member of International Advisory Board for the project consortium SFI Offshore Mechatronics, Norway Research Council & Norwegian Offshore and Drilling Engineering (NODE).

**Johnsson, Charlotta**

Chair of ISO TC184/SC5 (Industrial Automation / Interoperability, integration and architectures for enterprise systems and automation applications).

Member in ISO SMCC (Smart Manufacturing Coordination Committee).

Voting member in the standardization committee ISA95 and ISA88, and an information member in the standardization committee ISA99.

Member in SIS and SEK. She serves as the Swedish expert in the international IEC 62264, IEC 61512, ISO 22400 and ISO 15746 standards, as well as in the groups IEC AhG3, IEC TC65E AhG1, as well as in the joint committee IEC/TC65-ISO TC184 JWG21 (Reference Architecture for Smart Manufacturing).

**Rantzer, Anders**

Member of the IEEE Control Systems Award Committee.

Chairman of the IFAC Fellow Selection Committee.

Member of the Advisory Board for Lecture Notes in Control and Information Sciences at Springer Verlag Heidelberg.

Member of the IEEE Control System Society Technical Committee on Nonlinear Systems and Control.

Member of the IFAC Technical Committee on Nonlinear Systems.

**Robertsson, Anders**

Standardiseringskommitte SIS/TK268 Robotik, Stockholm.

Chair/organizer of session/workshop 3: Cyber-physical systems, ELLIIT conference, Karlskrona, October 15.

Co-organizer of 1st Lund-Chemnitz-Trondheim Summer School on Robotics, "*Motion planning and control*", August 5-9.

**Soltész, Kristian**

Active (first half of year) within the InnoVision initiative for a maker space on campus.

**OTHER ASSIGNMENTS****Årzén, Karl-Erik**

Associate Editor for Real-Time Systems Journal.

Associate Editor for the Leibnitz Transactions on Embedded Systems (LITES).

Associate Editor for ACM Transactions of Cyber-Physical Systems.

**Como, Giacomo**

Associate Editor of the IEEE Transactions on Control of Network Systems and of the IEEE Transactions on Network Science and Engineering.

**Johansson, Rolf**

Editor, Mathematical Biosciences, (Elsevier).

Editor, Intelligent Service Robotics (ISR), (Springer).

Associate Editor, International Journal of Adaptive Control and Signal Processing, (Wiley).

Associate Editor, Chinese Journal of Scientific Instrument, (China Instrument and Control Society).

Member of Editorial Board, Robotics and Biomimetics, (Springer).

Promotor, Doctoral Commencement (Sw. Promotion), Lund University, 24 May 2019.

**Johnsson, Charlotta**

Serving as the IFAC Liaison with IEC 65A.

**Maggio, Martina**

Member of the Editorial Board of the ACM Transactions on Embedded Computing, Associate Editor in the domain specific area of Self-Adaptive Embedded Systems.

**Robertsson, Anders**

Patent filed Dec 31, 2019 *Motor assembly for stictionless operation*, Application no: 19383219.3-1012, together with Joseph McIntyre, Rolf Johansson, Hubert Klein Julius.

**Westin, Eva**

Member in project group for TA future careers.

**LONGER VISITS ABROAD****Greiff Marcus**

During the summer of 2019, he was on a four month sabbatical, working for Mitsubishi Electric Research Laboratories (MERL).

**Maggio, Martina**

Spent 10 months at Bosch Corporate Research in Renningen (Stuttgart), Germany.

**Nayak Seetanadi, Gautham**

In November 2019, he was a teaching assistant in the *Automatic Control, basic course* given at Beihang University, China.

**Pates, Richard**

He visited Giacomo Como in Politecnico di Torino for three weeks in September as part of a thematic semester on Network Dynamics and Resilience.

He also spent time teaching the basic control course at Beihang University, Beijing, China.

**Robertsson, Anders**

During Oct/Nov 2019, he was teaching the basic control course given at Beihang University, China.

**Tegling, Emma**

Postdoctoral research is carried out at the Institute for Data, Systems, and Society at Massachusetts Institute of Technology (MIT) from July/August 2019.

## LECTURES BY STAFF OUTSIDE THE DEPARTMENT

### Årzén, Karl-Erik

*Control of Computer Systems*, Nordic IoT Summer School: Edge and Fog Computing, DTU, Lyngby, Jun 18.

*Control of Computer Systems*, 40th International Summer School of Automatic Control, Grenoble, France, Sep 9.

### Åström, Karl Johan

*Feedback Fundamentals*, University of Newcastle, New South Wales, Australia, Sept 3.

*Modeling and Model Based System Engineering*, Management Group Wilmar Sugar Mill, Sept 9.

*Feedback Fundamentals*, James Cook University, Townsville, Australia, Sept 9.

*PID Model Based Systems Engineering*, Wilmar Sugar Mill, Proserpine, Sept 10.

*Advances in PID Control*, Wilmar Sugar Mill, Proserpine, Sept 10.

### Cervin, Anton

*JitterTime – A tool for analyzing transient behavior in networked estimation and control applications*, 14th Cloud Control Workshop, Vindeln, April 3.

*Using JitterTime to Analyze Transient Performance in Adaptive and Reconfigurable Control Systems*, 24th International Conference on Emerging Technologies and Factory Automation, Zaragoza, Spain, September 12.

### Como, Giacomo

*On network games, dynamics, and intervention*, Computer Science Department, Università di Torino, (Torino, Italy), November 28, 2019. Invited presentation.

*Distributed Resilient Control of Dynamical Flow Networks*, Workshop on Resilient Control of Infrastructure Networks, Politecnico di Torino, (Torino, Italy), September 27, 2019. Invited presentation.

*Distributed Resilient Control of Dynamical Flow Networks*, Summer School Cascarix on "Cascading effects and risk management," (Autrans, France), September 3, 2019. Invited presentation.

*Distributed Resilient Control of Dynamic Flows in Transportation Networks*, 14th SICC International Tutorial Workshop "Modelling, Analysis, and Control of Complex Networks and Cyber-Physical Systems," (Ischia, Italy) June 30, 2019. Invited presentation.

*Distributed Resilient Control of Dynamic Flows in Transportation Networks*, Chalmers University, (Goteborg, Sweden), May 28, 2019. Invited presentation.

*Learning, multi-scale dynamics, and heterogeneities in network congestion games*, 9th EAI GAMENETS 2019, (Paris, France), April 25, 2019. Invited presentation.

*The mathematics of Networks and Games*, Applied Mathematics Campus, Marina di Massa (Italy), April 5-7, 2019. Invited presentation.

*On Resilient Control of Dynamical Flow Networks*, Seminar on Analysis, Design, and Control of Predictable Interconnected Systems, Leibnitz Zentrum für Informatics, (Schloss Dagstuhl, Germany), March 5, 2019. Invited presentation.

*On Controlled Diffusion in Evolutionary Network Dynamics*, Royal Institute of Technology (KTH), (Stockholm, Sweden), January 17, 2019. Invited presentation.

**Eker, Johan**

Keynote presentation at DAu (Danish Automation Society), Feb 27.

*Analysis, Design, and Control of Predictable Interconnected Systems*, Invited talk at Dagstuhl seminar March 2019.

Invited talk at Royal Institute of Technology, April 2019.

Keynote presentation at Fog-IoT 2019 - Workshop on Fog Computing and the Internet of Things at CPS Week in Montreal, April 2019.

Invited talk at WASP4ALI on the evolving cloud landscape, November 2019.

**Hägglund, Tore**

*Control of Industrial Processes*. Industrial course at Billerud - Grums, April 11.

*Control of Industrial Processes*. Industrial course at LKAB - Kiruna, June 13.

*A New Mid-Ranging Control Structure*. Nordic Process Control Workshop, Lyngby, Denmark, August 22.

*PID Controller Design*. Almeria, Spain, October 22. Invited lecture.

*Adaptive Control and Automatic Tuning*. Almeria, Spain, October 22. Invited lecture.

*Supervision and Detection*. Almeria, Spain, October 23. Invited lecture.

*Ratio Control and Mid-Ranging Control*. Almeria, Spain, October 23. Invited lecture.

**Johansson, Rolf**

*Robotik—Vetenskap eller Konst?*, SPF, Bjerred, Sweden, April 9. (Invited)

*Robotik & Internet of Things (IoT)*, LTH Veteraner, Lund University, Lund, Sweden, April 10. (Invited)

*Robotikrevolutionen*, Rotary, Staffanstorps, Sweden, April 11. (Invited)

**Johnsson, Charlotta**

*Standarder som möjliggörare för den smarta industrin*, coordinated by SIS, invited presentation at PiiA Summit, Västerås, Oct 8.

*Smart Manufacturing*. Invited presentation for Backer, Svedala, Sweden. September 10.

*Kirurgens perspektiv. Bildbehandling och robotic för 3D-grafik vid öppen hjärtkirurgi*. Invited Speaker at Digit@LTH, Lund, Sweden March 14.

*International Standardization and its relevance for Model Based Development*, keynote speaker at MODCON2019, Linköping, Feb 6.

*Innovation and Value Creation in Research*. Guest lecture of PhD-course at LTH, Lund University.

*Automation in Complex Systems*. Guest lecture of course at LTH, Lund University.

**Maggio, Martina**

*Feedback-Control for Self-Adaptive Predictable Computing*. Saarbruecken, MPI SWS, March 15. Invited Presentation.

*Feedback-Control for Self-Adaptive Predictable Computing*. Kaiserslautern, TU, March 26. Invited Presentation.

*Feedback-Control for Self-Adaptive Predictable Computing*. Saarbruecken, Saarland University, May 7. Invited Presentation.

*Feedback-Control for Self-Adaptive Predictable Computing*. Stuttgart, MPI Intelligent Systems, September 10. Invited Presentation.



**Pigot, Henry**

*A Self-Sustaining Model for Peer-to-Peer Engineering Education Among Children in Low Resource Environments*, IEEE PELS Vancouver Lunch and Learn Seminar, January 9. Invited speaker.

**Pates, Richard**

*Frequency control and reserves in large interconnected power systems including renewables*, Nordic 2020 - DNV GL Malmö, 18th June. Invited presentation.

*Modular control system design for platooning problems*, Politecnico di Torino, 19th September. Invited presentation.

*A Modular approach to control system design*, Beihang University, 29th November. Invited presentation.

*On the Optimal Control of Relaxation Systems*, Conference on Decision and Control (CDC), Nice, 13th December. Conference Presentation.

**Rantzer, Anders**

*Towards a Theory of Scalable Control*, Plenary lecture at 38th Benelux Meeting on Systems and Control, March 21.

*Adaptive Control — What can we learn?*, Plenary lecture at 38th Benelux Meeting on Systems and Control, March 21.

*Adaptive Control — What can we learn?*, Seminar at University of Illinois at Urbana Champaign, April 1.

*Adaptive Control — What can we learn?*, Seminar at University of California at Berkeley, April 1.

*Theory for Scalable Control*, WASP Faculty and industry day, Gothenburg, May 13.

*Realizability and Internal Model Control on Networks*, European Control Conference, June 28.

*Adaptive Control — What can we learn?*, ETH Zürich, July 2.

*Towards a Theory of Scalable Control*, DISMA workshop on Resilient Control of Infrastructure Networks, Politecnico di Torino, September 24.

*Optimization Based Approaches to Exploration/exploitation*, 58th IEEE Conference on Decision and Control, Nice, December 12.

**Robertsson, Anders**

*Robot force control and its applications*, 2 guest lectures at NTNU, Norway, April 3-4, 2019.

*Multi-robot coordination under various (even time-varying) motion constraints*, Seminar at Linköping University, October 3.

**Sun, Zhiyong**

Invited seminars at several universities in China, including:

*Conservation laws and invariance principles in networked control systems*. Peking University, Beijing, China, March 16.

*Cooperative coordination of multi-agent systems with motion constraints*. University of Electronic Science and Technology of China, Chengdu, China, December 20.

*Multi-robot coordination under various constraints*. East China University of Science and Technology, Shanghai, China, December 28.

**Tegling, Emma**

*Performance limitations of large-scale networks with distributed dynamic feedback.* University of Wisconsin-Madison, October 7. Invited seminar.

**Troeng, Olof**

*Perspectives on cavity field control,* Low-Level RF Workshop, Chicago, IL, October 3. Invited Presentation.

**POPULAR SCIENCE PRESENTATIONS****Johnsson, Charlotta**

*Fullsatt seminarium om standarder,* article in Swedish press Production 2030 nr 1.19, 2019-10.  
*Standarder för digitalisering",* article in Swedish press Production 2030 nr 1.19, 2019-10.

**Robertsson, Anders**

January 15; RobotLab demo for ScalABLE4.0 GA-meeting (25 persons).

February 13; RobotLab demo for KU Leuven Brugge (30 persons)

March 19; Natur-, Medicin- och Teknisdagarna på Lunds Universitet 4 x *Robotar, cyklar och andra svårstyrda saker* med ca 80 besökande till Lab och RobotLab.

April 8; RobtLab-demo Rotary St Knuts (16 persons).

April 8; RobtLab-demo Tekniksprånget på Volvo i Göteborg (15 persons).

May 2; ELLIIT-presentation on *Collaborative robots* to ELLIIT-board, Lund, Sweden.

June 20; Robotlab demo International Marketing and Recruitment, Division of External Relations. (5 persons).

August 13; Robotlab demo Vattenhallen lärarfortbildning (6 personer).

September 10; Guest lecture in Applied Mechatronics course, *Industry 4.0 and robotics*, LTH, Lund University.

November 19-21; EUrobotics week, Demo of RobotLab, LTH. 15 visiting school classes and 3 DIGIT@LTH-seminars.

November 22; Presentation RobotLab, LTH at workhop *VAMED: Digital construction at LTH*, construction robotics seminar.



