

ISSN 0280-5316
ISRN LUTFD2/TFRT--7559--SE

System Analysis via Integral Quadratic Constraints Part II

Anders Rantzer
Alexander Megretski

Department of Automatic Control
Lund Institute of Technology
September 1997

System Analysis via Integral Quadratic Constraints Part IIa: Abstract theory

A. Rantzer

Dept. of Automatic Control
Box 118
S-221 00 Lund
SWEDEN
email: rantzer@control.lth.se

A. Megretski

35-418 EECS MIT
Cambridge MA 02139
USA
email: ameg@mit.edu

Abstract

In this second report on system analysis via integral quadratic constraints, the theory is refined compared to Part I [6], to cover a number of additional cases. The report is split into two halves, denoted Part IIa and Part IIb.

Unbounded operators are treated by encapsulating them in a feedback loop, that has bounded closed loop gain. A general theorem for well-posedness of such feedback loops is given. A concept of “fading memory” is introduced and plays an important role in the study of exponential stability. It is also shown how system performance can be studied with restrictions on the class of input signals. In particular, for sinusoidal inputs, we compute bounds on high order harmonics in the system response.

1. Introduction

Stability criteria based on Lyapunov functions, dissipativity and absolute stability have been developed over several decades. However, a new perspective on the theory has recently emerged with the development of new numerical methods. For linear time-invariant systems with uncertainty, efficient computational tools have been developed based on the notion structured singular value, [4, 8]. For nonlinear and time-varying systems, the search for a quadratic Lyapunov function can be written as a convex optimization problem with linear matrix inequality (LMI) constraints. Such problems can be solved with great efficiency using interior point methods.

A large variety of results of this kind were recently unified and generalized using the notion integral quadratic constraint (IQC) [7]. The general computational problem to find multipliers that prove stability was stated as an LMI

optimization problem. Furthermore, it was shown that previous technical problems associated with anti-causal multipliers [3] can be avoided using a homotopy argument.

The approach in [7] involves three major steps of analysis. In the first step, the system is represented as a feedback interconnection of a known linear time-invariant (LTI) system of finite order, with transfer matrix $G(s)$, and a nonlinear, time-varying, and possibly uncertain operator Δ . In the second step, Δ is described in terms of IQC's, which means inequalities of the form

$$\int_{-\infty}^{\infty} \begin{bmatrix} \hat{v}(j\omega) \\ \hat{w}(j\omega) \end{bmatrix}^* \Pi(j\omega) \begin{bmatrix} \hat{v}(j\omega) \\ \hat{w}(j\omega) \end{bmatrix} d\omega \geq 0 \quad \forall w = \Delta(v), \quad (1)$$

relating the input and output of Δ *under the assumption* that both are square integrable. In many cases, such IQC's are readily available in the literature, though usually not in explicit form. In the third step, a matrix function $\Pi(j\omega)$ is sought, that satisfies both (1) and the condition

$$\begin{bmatrix} G(j\omega) \\ I \end{bmatrix}^* \Pi(j\omega) \begin{bmatrix} G(j\omega) \\ I \end{bmatrix} \leq -\varepsilon I \quad \forall \omega \quad (2)$$

with $\varepsilon > 0$. This search for Π can be reduced to solving a system of linear matrix inequalities (LMI's). If a solution exists, then the feedback system is stable, provided that certain general non-restrictive assumptions are satisfied by Π, Δ and G . In particular, it is assumed that there exists a homotopy, which continuously deforms the original feedback system into a simple stable interconnection. Both conditions (1),(2) and a well-posedness condition, must be satisfied along the homotopy path. In addition, Π, Δ and G must be bounded.

The paper is devoted to the exploration of the limits of applicability of the IQC analysis paradigm. A second goal is to make its application as care-free as possible. The outline of this first part of the paper is as follows. In section 2 some basic definitions and properties of multi-valued operators is given. Interconnections are defined in section 3 and a general criterion for well-posedness is proved. Integral quadratic constraints are defined in section 4 and used for verification of L_2 -stability. In section 5 the concept of fading memory is introduced as a means of proving exponential stability. Further investigations of system performance are made in section 6. In particular, we study the response to finite pulses and to sinusoidal inputs.

The second part of the paper is devoted to case studies. We show how to treat some less trivial nonlinearities, such as an ideal relay, a backlash and a rate limiter.

Notation

The notation L_{2e}^n is used for the linear space of all functions $f : (0, \infty) \rightarrow \mathbf{R}^n$ which are square integrable on any finite interval. The subspace consisting of square integrable functions is denoted L_2^n . Norm and inner product of such functions are denoted

$$\|f\| = \langle f, f \rangle^{1/2}, \quad \langle f, g \rangle = \int_0^{\infty} f(t)^* g(t) dt.$$

The notation \mathbf{A}^n is used for the space of absolutely continuous functions $f : (0, \infty) \rightarrow \mathbf{R}^n$.

The set of proper rational transfer matrices $G = G(s)$ of size k by m is denoted by $\mathbf{RL}_\infty^{k \times m}$. This is a subspace of $\mathbf{RC}_\infty^{k \times m}$, which consists of all matrix functions that are bounded and continuous on the imaginary axis. The subset of stable functions $G \in \mathbf{RL}_\infty^{k \times m}$ is denoted by $\mathbf{RH}_\infty^{k \times m}$. Each element $G \in \mathbf{RL}_\infty^{k \times m}$ is associated with a corresponding causal LTI operator $G : \mathbf{L}_{2e}^m \rightarrow \mathbf{L}_{2e}^k$, defined by

$$(Gf)(t) = Df(t) + \int_0^t C e^{\tau A} B f(t - \tau) d\tau$$

where $G(s) = C(sI - A)^{-1}B + D$. An element $G \in \mathbf{RL}_\infty^{k \times m}$ is called *strictly proper* if $D = 0$. For $a \leq b$ and $f \in \mathbf{L}_{2e}^k$, the projection $P_b^a f \in \mathbf{L}_{2e}^k$ is defined by

$$(P_b^a f)(t) = \begin{cases} f(t), & \max\{a, 0\} < t \leq b \\ 0, & \text{otherwise} \end{cases}$$

The shorthand $P_T f$ is used for $P_T^0 f$, and $P^T f$ means $P_\infty^T f$.

2. Multi-valued Operators

The word ‘‘operator’’ will be used to denote an input/output system. Mathematically, it simply means any function (possibly multi-valued) from one signal space \mathbf{L}_{2e}^k into another: an *operator* $\Delta : \mathbf{L}_{2e}^l \rightarrow \mathbf{L}_{2e}^m$ is defined by a subset $\mathcal{S}_\Delta \subset \mathbf{L}_{2e}^l \times \mathbf{L}_{2e}^m$ such that for every $v \in \mathbf{L}_{2e}^l$ there exists $w \in \mathbf{L}_{2e}^m$ with $(v, w) \in \mathcal{S}_\Delta$. The notation

$$w = \Delta(v) \tag{3}$$

means that $(v, w) \in \mathcal{S}_\Delta$.

In most examples the operators are defined by algebraic and differential equations. The notion of causality is introduced to represent existence and continuability of solutions of such equations forward in time: an operator Δ is said to be *causal* if the set of past projections $P_T w$ of possible outputs $w = \Delta(v)$ corresponding to a particular input v does not depend on the future $P^T v$ of the input, i.e. $\mathbf{P}_T \Delta = \mathbf{P}_T \Delta \mathbf{P}_T$ for all $T \geq 0$. The operator Δ is *affinely bounded* if there exists C_0 and C_1 such that

$$\|P_T w\| \leq C_0 + C_1 \|P_T v\| \quad \forall T > 0, w = \Delta(v), v \in \mathbf{L}_{2e}^l \tag{4}$$

It is called *bounded* if this holds with $C_0 = 0$. The *gain* $\|\Delta\|$ of Δ is then defined as the infimum of all C_1 for which the inequality holds with $C_0 = 0$.

We also need a notion of distance between two operators. For this, we define the *gap* between G and H as $\delta(G, H)$, where

$$\begin{aligned} \vec{\delta}(G, H) &:= \sup_{g \in \mathcal{S}_G} \inf_{h \in \mathcal{S}_H} \sup_{T > 0} \frac{\|P_T g - P_T h\|}{\|P_T g\|} \\ \delta(G, H) &:= \max(\vec{\delta}(G, H), \vec{\delta}(H, G)) \end{aligned}$$

and supremum in $T > 0$ is taken subject to the constraint that $\|P_T g\| \neq 0$. This definition of gap is very close to the one suggested by Georgiou and Smith in [5]. The notion of gap can be used to verify boundedness in the following way:

LEMMA 1

Let the operator Δ_0 be causal and bounded and let Δ be causal. If

$$\delta(\Delta_0, \Delta) < (2 + \|\Delta_0\|)^{-1}$$

then Δ is bounded. □

A proof is given in section 7.

The system G_τ is said to depend *continuously* on τ if $\delta(G_{\tau_1}, G_{\tau_2}) \rightarrow 0$ as $|\tau_1 - \tau_2| \rightarrow 0$. However, the definition has to be used with some caution, since the operator $(w_1, w_2) = (G_\tau(v), H_\tau(v))$ may depend continuously on τ even if G_τ or H_τ does not. Moreover τG may depend continuously on τ for $\tau > 0$ even if G is unbounded.

3. Interconnections

The main object of study in the paper is interconnections of operators, that is relations of the form

$$\begin{cases} v = G(w) + f \\ w = \Delta(v) + e \end{cases} \quad (5)$$

We say that the interconnection of the two operators $G : \mathbf{L}_{2e}^m \rightarrow \mathbf{L}_{2e}^l$ and $\Delta : \mathbf{L}_{2e}^l \rightarrow \mathbf{L}_{2e}^m$ is *well posed* if the set of all solutions to (5) defines a causal operator $[G, \Delta] : (f, e) \mapsto (v, w)$. The interconnection is called *stable* if in addition $[G, \Delta]$ is bounded.

LEMMA 2

If G_τ and Δ_τ depend continuously on τ , then so does $[G_\tau, \Delta_\tau]$. □

A proof is given in section 7.

In order to derive well-posedness of interconnections involving operators that are not open-loop bounded, such as the relay, hysteresis, dry friction, etc, we introduce two additional notions.

The operator F is called *incremental* if for any $T > 0$ there exist $C_0, C_1, \tau > 0$, and $\theta < 1$ such that

$$\|P_{t+\tau}F(v)\| \leq \theta\|P_{t+\tau}^t v\| + C_0 + C_1\|P_t v\| \quad (6)$$

for all $t \in [0, T]$, $v \in \mathbf{L}_{2e}$.

We write $w_i \rightarrow^* w$ if $\sup \|w_i - w\| < \infty$ and $\langle g, w_i - w \rangle \rightarrow 0$ for every $g \in \mathbf{L}_2^n$. An operator F is said to be *locally *-continuous* if for every $t > 0$ there exists $d > 0$ such that from every input-output sequence $w_i = F(v_i)$ with $P_{t-d}(w_i - w_0) = 0$, $P_{t-d}(v_i - v_0) = 0$, and $P_{t+d}v_i \rightarrow^* P_{t+d}v$, one can extract a subsequence $w_{i(j)}$ such that $P_{t+d}w_{i(j)} \rightarrow^* w$ and $P_{t+d}w = P_{t+d}F(v)$.

Note that a composition of two incremental operators is incremental and a composition of two locally *-continuous operators is itself locally *-continuous.

THEOREM 1

Let $F : \mathbf{L}_{2e}^n \rightarrow \mathbf{L}_{2e}^n$ be a causal operator which is both locally *-continuous and incremental. Then the equation $w = F(w + v)$ has a solution for every $v \in \mathbf{L}_{2e}^n$, and the corresponding operator $v \mapsto w$ is causal and locally *-continuous.

Moreover, if F is a composition of the form $\Delta \circ G$ or $G \circ \Delta$, where $G \in \mathbf{RH}_\infty$ is strictly proper and Δ is affinely bounded, then both F and the operator $v \mapsto w$ are incremental. \square

A proof is given in section 7.

Theorem 1 is a general result which helps to establish well-posedness of various interconnections. The following corollary describes an important special case when the theorem can be applied.

Let ϕ be a function, that maps \mathbf{R}^n into the set \mathcal{S}^n of convex compact subsets of \mathbf{R}^n . The map is said to be continuous if

$$z_i \in \phi(x_i), x_i \rightarrow x, z_i \rightarrow z \Rightarrow z \in \phi(x)$$

COROLLARY 1

Let $\phi : \mathbf{R}^n \rightarrow \mathcal{S}^n$ be affinely bounded and continuous. Then, for every $f \in \mathbf{L}_{2e}^n$, the equation $\dot{x} = \phi(x) + f$, $x(0) = x_0$ has a solution. \square

4. Stability via Integral Quadratic Constraints

A functional $\sigma : \mathbf{L}_2^n \rightarrow \mathbf{R}$ is called *quadratically continuous* if for every $\varepsilon > 0$ there exists $C > 0$ such that

$$\sigma(h) \leq \sigma(g) + \varepsilon \|g\|^2 + C \|h - g\|^2 \quad \forall g, h \in \mathbf{L}_2^n \quad (7)$$

The operator $\Delta : \mathbf{L}_{2e}^l \rightarrow \mathbf{L}_{2e}^m$ is said to satisfy the *integral quadratic constraint* (IQC) defined by σ if

$$\sigma(h) \geq 0 \quad \forall h = (v, \Delta(v)) \in \mathbf{L}_2^{l+m}$$

The following theorem shows how such constraints can be used to verify stability.

THEOREM 2

Let $\sigma : \mathbf{L}_2^{l+m} \rightarrow \mathbf{R}$ be quadratically continuous. Suppose that the interconnection of $G_\tau : \mathbf{L}_{2e}^m \rightarrow \mathbf{L}_{2e}^l$ and $\Delta_\tau : \mathbf{L}_{2e}^l \rightarrow \mathbf{L}_{2e}^m$ is stable for $\tau = 0$ and well posed for $\tau \in [0, 1]$. If G_τ and Δ_τ depend continuously on τ and for all $\tau \in [0, 1]$

$$\sigma(g) \leq -2\varepsilon \|g\|^2 \quad \forall g = (G_\tau(w), w) \in \mathbf{L}_2^{l+m} \quad (8)$$

$$\sigma(h) \geq 0 \quad \forall h = (v, \Delta_\tau(v)) \in \mathbf{L}_2^{l+m} \quad (9)$$

then the feedback interconnection of G_1 and Δ_1 is stable. \square

A proof is given in section 7.

Integral quadratic constraints are most often used on the form (1), where $\Pi(j\omega)$ is a bounded Hermitean $k + m$ by $k + m$ matrix-valued function. The corresponding functional will be denoted σ_Π . If the operator G is replaced by a transfer matrix $G(s)$, then the stability criterion can be written on the following form, recognized from Theorem 2 in [7].

COROLLARY 2

Consider $G \in \mathbf{RH}_\infty^{l \times m}$ and a causal, bounded operator $\Delta : \mathbf{L}_{2e}^l \rightarrow \mathbf{L}_{2e}^m$ such that $\Delta \circ G$ is locally *-continuous and incremental. Suppose that there exist $\Pi \in \mathbf{RH}_\infty^{(l+m) \times (l+m)}$, $\varepsilon > 0$ and $\sigma_\Pi(0, w) + \varepsilon \|w\|^2 \leq 0 \leq \sigma_\Pi(v, 0)$ for all v, w . If

$$\begin{bmatrix} G(j\omega) \\ I \end{bmatrix}^* \Pi(j\omega) \begin{bmatrix} G(j\omega) \\ I \end{bmatrix} \leq -\varepsilon I \quad \forall \omega \in \mathbf{R} \quad (10)$$

$$\sigma_\Pi(v, \Delta(v)) \geq 0 \quad \forall v \in \mathbf{L}_2^l[0, \infty) \quad (11)$$

then the interconnection of G and Δ is stable. \square

A proof is given in section 7.

An alternative to the condition $\sigma_\Pi(0, w) + \varepsilon \|w\|^2 \leq 0$ is to assume existence of some $G_0 \in \mathbf{RH}_\infty^{l \times m}$ such that (10) holds with G replaced by G_0 and the interconnection of G_0 and Δ is stable. The conditions above are recovered with $G_0 = 0$.

The necessity of the inequalities $\sigma_\Pi(0, w) + \varepsilon \|w\|^2 \leq 0 \leq \sigma_\Pi(v, 0)$ is illustrated in the following example.

Example 1 Let $m = l = 1$, $\Delta(v) = v$, $G(s) = 2/(s + 1)$ and

$$\sigma_\Pi(v, w) = \left\| v - \frac{2}{s+1}w \right\|^2 - \frac{1}{2}\|w\|^2$$

Then all conditions of Corollary 2 hold, except the inequality $\sigma_\Pi(0, w) + \varepsilon \|w\|^2 \leq 0$, but the interconnection of G and Δ is unstable. If G, Δ are the same, but

$$\sigma(v, w) = 0.2\|v\|^2 - \|v - w\|^2$$

then all conditions hold except the inequality $0 \leq \sigma_\Pi(v, 0)$. \square

5. Exponential stability

In some applications, it is important to prove exponential stability rather than \mathbf{L}_2 -stability. For example, in systems with hysteresis, there may be infinitely many possible equilibria and the role of stability theory is to prove decay of the signal derivatives, rather than the signals themselves. However, \mathbf{L}_2 -bounded derivatives is not sufficient for convergence of the signals. Therefore, it is desirable to prove exponential decay as well.

For this reason, we call the operator Δ *exponentially bounded* if there exist $a > 0$ and $C > 0$ such that

$$\|e^{at}P_T w\| \leq C \|e^{at}P_T v\| \quad \forall T > 0, w = \Delta(v), v \in \mathbf{L}_{2e}^l \quad (12)$$

LEMMA 3

If (12) holds with some $a > 0$ then it also holds with a replaced by any $b \in [0, a]$, with the same constant C . In particular, Δ is bounded if Δ is exponentially bounded. \square

A proof is given in section 7.

For proofs of exponential stability of feedback systems, the following concept will be used: the operator Δ is said to have *fading memory* if there exist $C_f > 0$ and $a, b > 0$ such that for every $h = (v, \Delta(v)) \in \mathbf{L}_{2e}^{l+m}$ and for every $\tau \geq 0$ there exists $h_\tau = (v_\tau, \Delta(v_\tau))$ such that $P_{\tau-b}h_\tau = 0$, $P^\tau h_\tau = P^\tau h$ and

$$\|P_\tau h_\tau\| \leq C_f \|e^{a(t-\tau)} P_\tau h\| \quad (13)$$

The fading memory condition is somehow related to controllability and observability, since only the “unexposed” memory needs to be fading. For example, a pure integrator is unbounded but will be shown to have fading memory. In contrast, the composition $(1/s) \circ \text{sat}$ of a pure integrator and saturation does not have fading memory. To see this, apply non-zero constant input at the saturation level. The example shows that a composition of two operators with fading memory does not necessarily have fading memory itself.

The next two lemmata state important facts about the concept fading memory. The first one gives a condition for fading memory, assuming existence of the following type of state space realization. Let the causal operator $w = \Delta(v)$ have a representation of the form

$$x = \Delta_x(v) \quad w(t) = h(x(t), v(t))$$

where $h : \mathbf{R}^n \times \mathbf{R}^l \rightarrow \mathbf{R}^m$ and $\Delta_x : \mathbf{L}_{2e}^l \rightarrow \mathbf{A}^n$ is causal, while $\Delta_x(0) = 0$ and

$$\begin{cases} x_1 = \Delta_x(v_1), & x_2 = \Delta_x(v_2) \\ x_1(\tau) = x_2(\tau) \\ P^\tau v_1 = P^\tau v_2 \end{cases} \quad \Rightarrow \quad P^\tau x_1 = P^\tau x_2$$

LEMMA 4

Assume existence of a state space realization. If the system is detectable and reachable in the sense that there exists $b, c > 0$ such that

$$|x(\tau)| \leq c \|P_\tau^{\tau-b}(w, v)\| \quad \forall \tau > 0, v \in \mathbf{L}_{2e}^l \quad (14)$$

and for every x_0 , $\tau > 0$, there exists v with $P_{\tau-b}v = 0$, such that

$$x(\tau) = x_0 \quad \|P_\tau^{\tau-b}(w, v)\| \leq c |x_0| \quad (15)$$

then Δ has fading memory. □

COROLLARY 3

Every linear time-invariant operator of finite order has fading memory. □

LEMMA 5

Every bounded operator with fading memory is exponentially bounded. □

Proofs of Lemma 4 and 5 are given in section 7.

The interconnection is called *exponentially stable* if it is well-posed and $[G, \Delta]$ is exponentially bounded. It is straightforward to verify that $[G, \Delta]$ has fading memory whenever G and Δ do so. Hence, Lemma 5 can be reformulated in terms of stability as follows.

COROLLARY 4

If G and Δ have fading memory and their interconnection is stable, then the interconnection is exponentially stable. \square

6. Performance Analysis

The objective of the previous sections was to use integral quadratic constraints to prove the stability. In this way, the size of system variables v, w was bounded by the size of the disturbances e, f . However, no properties of the disturbance variables other than their L_2 -norm were used. The objective of this section is to show how such information can be used to improve the bounds.

Assume that a feedback system has been proved to be stable and that a number of integral quadratic constraints are available:

$$\sigma_1(h) \geq 0, \dots, \sigma_n(h) \geq 0 \quad \forall h \in [G, \Delta] \quad (16)$$

Some of these constraints may describe nonlinear or uncertain components, while others represent properties of external signals. Using this information, we would like to make a conclusion about the system performance, represented by another quadratic inequality.

$$\sigma_0(h) \leq 0 \quad h \in [G, \Delta] \quad (17)$$

This is the standard setup for the so called *S-procedure*, observing that (17) follows from (16) if there exists numbers $\tau_1, \dots, \tau_n \geq 0$ such that

$$\sigma_0(h) + \sum_k \tau_k \sigma_k(h) \leq 0 \quad \forall h \in \mathbf{L}_{2e}^n[0, \infty) \quad (18)$$

We will illustrate this simple idea in two different cases. The first objective is to estimate L_2 -gain when the input is a pulse of the form

$$u(t) = \begin{cases} 1 & t \in [0, T] \\ 0 & \text{otherwise} \end{cases} \quad (19)$$

where $T \leq T_0$. Such signals have norm

$$T = \frac{1}{2\pi} \int_{-\infty}^{\infty} |\hat{u}|^2 d\omega$$

while the energy in the low frequency interval $|\omega| < \omega_0$ is estimated by

$$\int_{-\omega_0}^{\omega_0} |\hat{u}|^2 d\omega = \int \left(\frac{2 \sin \omega T}{\omega} \right)^2 d\omega \leq \int (2T)^2 d\omega = 8T^2 \omega_0 \leq 8TT_0 \omega_0$$

The result can be restated as follows.

PROPOSITION 1

Signals of the form (19) with $T \leq T_0$ satisfy the IQC:

$$0 \leq \sigma_1(u) := \frac{4T_0\omega_0}{\pi} \int_{-\infty}^{\infty} |\hat{u}|^2 d\omega - \int_{-\omega_0}^{\omega_0} |\hat{u}|^2 d\omega$$

\square

This gives, via the S-procedure, a bound on the L_2 -gain of a transfer function $G(s)$ applied to pulses of the form (19).

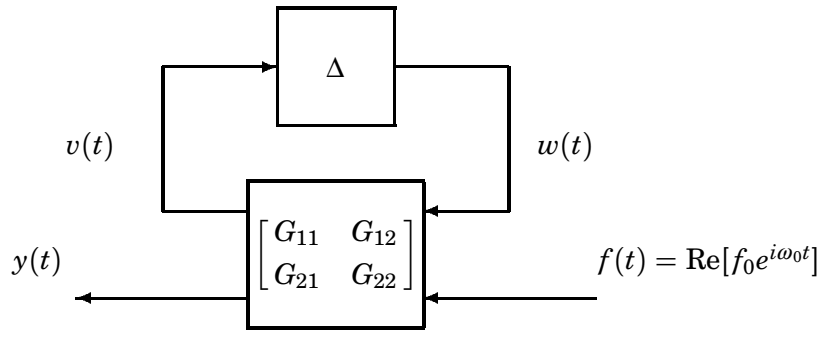

Figure 1 Feedback loop with sinusoidal excitation

COROLLARY 5

Suppose that $G \in \mathbf{RH}_\infty$ and u satisfies (19). Then, for every $\omega_0 > 0$

$$\frac{\int_{-\infty}^{\infty} |G\hat{u}|^2 d\omega}{\int_{-\infty}^{\infty} |\hat{u}|^2 d\omega} \leq \frac{4T_0\omega_0}{\pi} \sup_{|\omega| < \omega_0} |G(i\omega)|^2 + \left(1 - \frac{4T_0\omega_0}{\pi}\right) \sup_{|\omega| > \omega_0} |G(i\omega)|^2$$

□

Proof. Let

$$\begin{aligned} \sigma_0(u) &= \|Gu\|^2 - \gamma^2 \|u\|^2 \\ \tau &= \frac{\gamma^2 - \max_{\omega > \omega_0} |G|^2}{4T_0\omega_0/\pi} = \frac{\max_{\omega < \omega_0} |G|^2 - \gamma^2}{1 - 4T_0\omega_0/\pi} \end{aligned}$$

Then $0 \geq \sigma_0(u) + \tau \sigma_1(u)$ and the result follows by the S-procedure. □

Next we will make a similar analysis for sinusoidal inputs. Two cases will be addressed. In the first case, a steady state situation is considered and it is assumed that all signals are periodic. Note however, that this does not follow from boundedness of the corresponding closed-loop operator. In the second case, it is shown how IQC's can be used to verify such an assumption.

In a periodic steady-state situation, the following result can be applied. Consider the system

$$\begin{cases} \begin{bmatrix} v \\ y \end{bmatrix} = \begin{bmatrix} G_{11} & G_{12} \\ G_{21} & G_{22} \end{bmatrix} \begin{bmatrix} w \\ f \end{bmatrix} \\ w = \Delta(v) \end{cases}$$

See Figure 1. For notational simplicity, assume that G_{21} is invertible and introduce for $k \geq 0$

$$\begin{aligned} \begin{bmatrix} K_k & L_k \\ (L_k)' & M_k \end{bmatrix} &= H(i\omega_k)^* \Pi(i\omega_k) H(i\omega_k) && \text{where} \\ H &= \begin{bmatrix} G_{11} & G_{12} \\ 0 & I \end{bmatrix} \begin{bmatrix} G_{21} & G_{22} \\ 0 & I \end{bmatrix}^{-1} \end{aligned}$$

THEOREM 3

Suppose $G \in \mathbf{RH}_\infty^{l \times m}$, while $\Delta : \mathbf{L}_{2e}^l \rightarrow \mathbf{L}_{2e}^m$ and $[G, \Delta]$ are causal, bounded and have fading memory. Assume $f(t) = \text{Re}[f_0 e^{i\omega_0 t}]$ and $w(t) = \text{Re}[\sum_{k=0}^\infty w_k e^{i\omega_k t}]$ with $\sum_k |w_k|^2 < \infty$ and all $\omega_k > 0$ different. If the inequalities (10) and (11) hold, then

$$|w_0| \leq \frac{|L_0| + \sqrt{|L_0|^2 + M_0 K_0}}{|K_0|} |f_0| \quad \text{for } l = m = 1 \quad (20)$$

$$|w_k|^2 \leq \frac{\|M_0 - (L_0)' K_0^{-1} L_0\|}{\|K_k\|} |f_0|^2 \quad \text{for } k \geq 1 \quad (21)$$

Moreover, if (10) and (11) hold with Π replaced by Π_j for $j = 1, \dots, n$, let K_k^j, L_k^j, M_k^j be defined accordingly. Then, the bound $|w_k| < \gamma |f_0|$ holds for every γ that together with some $\tau_1 > 0, \dots, \tau_m > 0$ satisfies inequality

$$0 > \begin{bmatrix} I & 0 \\ 0 & -\gamma^2 I \end{bmatrix} + \sum_{j=1}^n \tau_j \begin{bmatrix} K_0^j & L_0^j \\ (L_0^j)' & M_0^j \end{bmatrix} \quad \text{if } k = 0 \quad (22)$$

$$0 > \begin{bmatrix} 0 & 0 & 0 \\ 0 & -\gamma^2 I & 0 \\ 0 & 0 & I \end{bmatrix} + \sum_{j=1}^n \tau_j \begin{bmatrix} K_0^j & L_0^j & 0 \\ (L_0^j)' & M_0^j & 0 \\ 0 & 0 & K_k^j \end{bmatrix} \quad \text{if } k \geq 1 \quad (23)$$

□

A proof is given in section 7.

COROLLARY 6

Let $G(i\omega) = C(i\omega I - A)^{-1}B$ and let $\phi : \mathbf{R} \rightarrow \mathbf{R}$ with $0 \leq \phi(v)v \leq cv^2$ for all v . Suppose that A is Hurwitz, $\text{Re } G(i\omega) > 1/c$ for all ω and the system

$$\dot{x} = Ax - B[\phi(Cx) + a_0 \sin \omega_0 t] \quad y = Cx$$

has a solution of the form $y(t) = \sum_{k=0}^\infty b_k \sin(\omega_k t + \theta_k)$. Then

$$|b_0| \leq \frac{|G(i\omega_0)| + 1/c}{\text{Re } G(i\omega_0) + 1/c} |G(i\omega_0)| \cdot |a_0|$$

$$|b_k| \leq \frac{|G(i\omega_k)| \cdot |G(i\omega_0)|}{2\sqrt{(\text{Re } G(i\omega_k) + 1/c)(\text{Re } G(i\omega_0) + 1/c)}} |a_0| \quad \text{for } \omega_k \neq \omega_0$$

□

Proof. Theorem 3 can be applied with $f = a_0 \sin \omega_0 t$, $\Delta(v) = -\phi(v)$ and

$$\Pi(i\omega) = \begin{bmatrix} 0 & -1 \\ -1 & -2/c \end{bmatrix}$$

$$H = \begin{bmatrix} G & G \\ 1 & 0 \end{bmatrix} \begin{bmatrix} G & G \\ 0 & 1 \end{bmatrix}^{-1} = \begin{bmatrix} 1 & 0 \\ 1/G & -1 \end{bmatrix}$$

$$\begin{bmatrix} K_l & L_l \\ (L_l)' & M_l \end{bmatrix} = \begin{bmatrix} -2(\text{Re } G^{-1} + |G|^{-2}/c) & 1 + 2(G^{-1})'/c \\ 1 + 2G^{-1}/c & -2/c \end{bmatrix}$$

The desired bounds are obtained from (20) and (21). □

To derive conditions for convergence towards a periodic steady state, consider again a system model of the form

$$v = G\Delta(v) + f$$

where f is the sum of a periodic component and a finite energy component, where the second can be used to represent non-zero initial conditions.

Let the operator ∇_T be the shift by T , where T is the period of the periodic part of f . We then have

$$v - \nabla_T v = G[\Delta(v) - \Delta(\nabla_T v)] + g$$

where $g = f - \nabla_T f$ is square summable. Our objective is to prove that also $v - \nabla_T v$ is square summable. This problem can be reduced to the standard setup, by introducing the operator Δ_1 such that

$$\Delta(v) - \Delta(\nabla_T v) = \Delta_1(v - \nabla_T v)$$

If Δ is Lipschitz, then Δ_1 is bounded. In addition, Δ_1 will often satisfy some other IQC's depending on T . An example of this will be given in Part B of this paper. Moreover, it will be shown that a similar argument can be used to prove uniqueness of the periodic steady state orbit.

7. Proofs

Proof of Lemma 1 Let $\delta_0 = \delta(\Delta_0, \Delta)$ and $\gamma = \|\Delta_0\|$. Given any $h = (v, \Delta(v))$, by the definition of gap, there exists $h_0 = (v_0, \Delta_0(v_0))$ such that

$$\|P_T(h - h_0)\| \leq \delta_0 \|P_T h\| \quad \forall T > 0$$

Hence, by the triangle inequality and the definition of gain

$$\begin{aligned} \|P_T h\| &\leq \|P_T h_0\| + \|P_T(h - h_0)\| \\ &\leq (1 + \gamma)\|P_T v_0\| + \|P_T(h - h_0)\| \\ &\leq (1 + \gamma)\|P_T v\| + (2 + \gamma)\|P_T(h - h_0)\| \\ &\leq (1 + \gamma)\|P_T v\| + (2 + \gamma)\delta_0 \|P_T h\| \\ \|P_T h\| &\leq [1 - (2 + \gamma)\delta_0]^{-1} (1 + \gamma)\|P_T v\| \end{aligned}$$

This proves boundedness of Δ . □

Proof of Lemma 2. Let $\|f\|_T = \|P_T f\|$ for every f . Suppose that

$$\begin{cases} v_0 = G_{\tau_0}(w_0) + f_0 \\ w_0 = \Delta_{\tau_0}(v_0) + e_0 \end{cases} \quad (24)$$

and let $\mu > 0$. By definition of continuity, there exists $\varepsilon > 0$ such that for every τ with $|\tau - \tau_0| < \varepsilon$ there exist v and w satisfying

$$\begin{aligned} \|w - w_0\|_T + \|G_\tau(w) - G_{\tau_0}(w_0)\|_T &\leq \mu \|w_0\|_T + \mu \|G_{\tau_0}(w_0)\|_T \\ \|v - v_0\|_T + \|\Delta_\tau(v) - \Delta_{\tau_0}(v_0)\|_T &\leq \mu \|v_0\|_T + \mu \|\Delta_{\tau_0}(v_0)\|_T \end{aligned}$$

Define

$$\begin{aligned} e &:= w - \Delta_\tau(v) \\ f &:= v - G_\tau(w) \end{aligned}$$

Then

$$\begin{aligned} &\|(e, f, v, w) - (e_0, f_0, v_0, w_0)\|_T \\ &\leq 2\|w - w_0\|_T + 2\|v - v_0\|_T + \|\Delta_\tau(v) - \Delta_{\tau_0}(v_0)\|_T + \|G_\tau(w) - G_{\tau_0}(w_0)\|_T \\ &\leq 2\mu (\|v_0\|_T + \|w_0\|_T + \|\Delta_{\tau_0}(v_0)\|_T + \|G_{\tau_0}(w_0)\|_T) \\ &\leq 12\mu \|(e_0, f_0, v_0, w_0)\|_T \end{aligned}$$

so $\vec{\delta}([G_{\tau_0}, \Delta_{\tau_0}], [G_\tau, \Delta_\tau]) \leq 12\mu$. The inequality $\vec{\delta}([G_\tau, \Delta_\tau], [G_{\tau_0}, \Delta_{\tau_0}]) \leq 12\mu$ is analogous, so the proof is complete. \square

The essential part of the proof of Theorem 1 is covered by the following result.

LEMMA 6

Let F be a causal operator which is incremental and *-continuous. Then the equation $w = F(w)$ has a solution w and the inequality

$$\|P_t w\| \leq \frac{C_0}{C_1} \left(1 + \frac{C_1}{1 - \theta}\right)^{1 + \frac{t}{\tau}} \quad (25)$$

where τ, C_0, C_1, θ are the constants from (6), holds for every $w = F(w)$. \square

Proof. We start by proving the inequality (25). If $w = F(w)$, then (6) with $t = (k-1)\tau$, $k = 1, 2, \dots$ yields

$$\|P_{k\tau}^{(k-1)\tau} w\| \leq \|P_{k\tau} F(w)\| \leq \theta \|P_{k\tau}^{(k-1)\tau} w\| + C_0 + C_1 \|P_{(k-1)\tau} w\|$$

In other words,

$$\mu_k \leq a + b \sum_{l=1}^{k-1} \mu_l, \quad (26)$$

where $\mu_k = \|P_{k\tau}^{(k-1)\tau} w\|$, $a = C_0/(1 - \theta)$, and $b = C_1/(1 - \theta)$. It is easy to check that the recursive inequality (26) yields

$$\mu_k \leq a(b+1)^{k-1} \quad \sum_{l=1}^k \mu_l \leq \frac{a}{b} (b+1)^k,$$

which in turn implies (25).

To prove existence of a solution of $w = F(w)$, let D_n for $n = 1, 2, \dots$ be the operator of delay by $1/n$:

$$(D_n w)(t) = \begin{cases} w(t - 1/n) & t > 1/n \\ 0 & \text{otherwise} \end{cases}$$

Then the equation $w = D_n F(w)$, thanks to the presence of the delay, has a solution $w = w_n$ for any n . This solution is defined recursively, first on the

interval $t \in (0, 1/n)$, then on the interval $t \in (1/n, 2/n)$, etc. Since (6) is satisfied for F , it will also be satisfied with the same constants for F replaced by $D_n F$, because

$$\|P_{t+1/n} D_n v\| \leq \|P_{t+1/n} v\| \quad \forall t, v$$

Hence, the inequality (25) shows that $\sup_n \|P_T w_n\| < \infty$ for every $T > 0$ and therefore there exists a weakly convergent subsequence $P_T w_{n(i)} \rightarrow^* P_T w$ of $P_T w_n$.

Let the interval $[0, T]$ be covered by a finite number of intervals $(r_k, s_k) = (t_k - d(t_k), t_k + d(t_k))$, where $d(t) > 0$ is the number from the definition of local *-continuity. For $k = 1$ it follows from the *-continuity of F that there exists a weakly convergent subsequence $P_{s_1} v_{n(i)} \rightarrow^* P_{s_1} v = P_{s_1} F(w)$, where v_n are defined by $v_n = F(w_n)$. By (6), $\sup_n \|P_T v_n\| < \infty$ follows from the corresponding inequality for w_n . Hence, for every $0 < a < b < s_1$

$$\begin{aligned} \int_a^b (v - w) dt &= \lim_{n \rightarrow \infty} \int_a^b (v_n - w_n) dt \\ &= \lim_{n \rightarrow \infty} \int_a^b (v_n - D_n v_n) dt \\ &= \lim_{n \rightarrow \infty} \left(\int_a^b v_n dt - \int_{a-1/n}^{b-1/n} v_n dt \right) = 0 \end{aligned}$$

and it follows that $P_{s_1} w = P_{s_1} v = P_{s_1} F(w)$.

The same argument can now be used repeatedly with F replaced by

$$F_k(u) = P_{s_k} F(P_{r_k} w + P^{r_k} u) \quad k = 2, 3, \dots$$

to solve $P_{s_k} w = P_{s_k} F(w)$. This gives $P_T w = P_T F(w)$ and the procedure can be repeated indefinitely in order to solve $w = F(w)$ over the whole real line. \square

Proof of Theorem 1. Existence follows from Lemma 6 with F replaced by $F_0(w) = F(w + v)$. In the same way, causality follows with F replaced by $F_t(u) = F(P_t w + v + P^t u)$. The local *-continuity follows directly from the local *-continuity of F .

Let $G(s) = \int_0^\infty e^{-st} g(t) dt$ and $G_\tau(s) = \int_0^\tau e^{-st} g(t) dt$. That the compositions $\Delta \circ G$ and $G \circ \Delta$ are incremental then follows from the inequalities

$$\begin{aligned} \|P_{t+\tau} \Delta(Gw)\| &\leq \|\Delta(P_{t+\tau}(Gw))\| \\ &\leq c_0 + c_1 \|P_{t+\tau} Gw\| \\ &= c_0 + c_1 \|P_{t+\tau} ((P_\tau g) * P_{t+\tau}^t w + g * P_t w)\| \\ &\leq c_0 + c_1 \|G_\tau\|_\infty \cdot \|P_{t+\tau}^t w\| + c_1 \|G\|_\infty \cdot \|P_t w\| \end{aligned}$$

$$\begin{aligned} \|P_{t+\tau} G \Delta(w)\| &= \|P_{t+\tau} ((P_\tau g) * P_{t+\tau}^t \Delta(w) + g * P_t \Delta(w))\| \\ &\leq \|G_\tau\|_\infty \cdot \|\Delta(P_{t+\tau}^t w)\| + \|G\|_\infty \cdot \|\Delta(P_t w)\| \\ &\leq \|G_\tau\|_\infty (c_0 + c_1 \|P_{t+\tau}^t w\|) + \|G\|_\infty (c_0 + c_1 \|P_t w\|) \end{aligned}$$

where $\theta = c_1 \|G_\tau\|_\infty < 1$ when τ is sufficiently small. To see that the corresponding operator $v \mapsto w$ is incremental, rewrite the incrementality inequality for F

as

$$\begin{aligned}
\|P_{t+\tau}w\| &= \|P_{t+\tau}F(w+v)\| \\
&\leq \theta\|P_{t+\tau}^t w\| + \theta\|P_{t+\tau}^t v\| + C_0 + C_1\|P_t(w+v)\| \\
\|P_{t+\tau}w\| &\leq \frac{1}{1-\theta} (\theta\|P_{t+\tau}^t v\| + C_0 + C_1\|P_t w\| + C_1\|P_t v\|)
\end{aligned}$$

Here $\theta/(1-\theta) < 1$ when τ is selected sufficiently small and the term $C_1\|P_t w\|$ can be removed by applying the inequality recursively over the sequence of intervals $[0, \tau]$, $[\tau, 2\tau]$, $[2\tau, 3\tau]$, \dots \square

Proof of Corollary 1. Let $w = \Delta_\phi(v)$ be the operator defined by the relation

$$w(t) \in \phi(v(t)) \quad \forall t$$

The system $\dot{x} = \phi(x) + f$ can be written as $w = F(w+v)$, where

$$F = \frac{1}{s} \circ \Delta_\phi \quad w = x - \frac{1}{s}f - x_0 \quad v = \frac{1}{s}f + x_0$$

Hence Theorem 1 can be applied. \square

Proof of Theorem 2. Note that combination of (5), (7), (8) and (9) gives

$$\begin{aligned}
0 &\leq \sigma(h) \\
&\leq \sigma(g) + \varepsilon\|g\|^2 + C\|h-g\|^2 \\
&\leq -\varepsilon\|g\|^2 + C\|h-g\|^2 \\
&= -\varepsilon(\|w\|^2 + \|G_\tau(w)\|^2) + C(\|e\|^2 + \|f\|^2) \\
&\leq -\varepsilon(\|w\|^2 + \|v\|^2)/2 + (\varepsilon + C)(\|e\|^2 + \|f\|^2)
\end{aligned} \tag{27}$$

where the last inequality uses that $|v|^2/2 \leq |v-f|^2 + |f|^2$. Hence for any τ such that the interconnection of G_τ and Δ_τ is stable, the gain of $[G_\tau, \Delta_\tau]$ is not larger than $\sqrt{2(1+C/\varepsilon)}$. By the continuous τ -dependence in G_τ and Δ_τ , there exists a $d > 0$ such that

$$\delta([G_{\tau_1}, \Delta_{\tau_1}], [G_{\tau_2}, \Delta_{\tau_2}]) < (2 + \sqrt{2(1+C/\varepsilon)})^{-1} \quad \text{when } |\tau_1 - \tau_2| < d$$

Lemma 1 can therefore be used repeatedly to prove boundedness of $[G_\tau, \Delta_\tau]$ for τ in the intervals $[0, d]$, $[d, 2d]$, $[2d, 3d]$ and so on, until the whole segment $[0, 1]$ is covered. \square

Proof of Corollary 2. To apply Theorem 2, we let the operator G_τ be defined by the transfer matrix $\tau G(s)$. Then the interconnection is stable for $\tau = 0$ and by Theorem 1 it is well-posed for $\tau \in [0, 1]$. In addition, G_τ depends continuously on τ , since

$$\frac{\|P_T(G_{\tau_1}(w), w) - P_T(G_{\tau_2}(w), w)\|}{\|P_T(G_{\tau_1}(w), w)\|} \leq \frac{\|(\tau_1 - \tau_2)P_T G w\|}{\|P_T w\|} \leq |\tau_1 - \tau_2| \cdot \|G\|_\infty$$

Condition (11) implies (9). For $\tau = 1$, (10) implies (8). The inequality $\sigma_\Pi(0, w) \leq -\varepsilon\|w\|^2$ shows that (8) holds also for $\tau = 0$. Finally, the inequality $0 \leq \sigma_\Pi(v, 0)$ shows that $\sigma_\Pi(\tau G w, w)$ is convex in τ so (8) must hold for all $\tau \in [0, 1]$. \square

Proof of Lemma 3. Partial integration gives for every $\varepsilon \in [0, a]$

$$\begin{aligned}
\int_0^T e^{2\varepsilon t} |w|^2 dt &= \int_0^T e^{2(\varepsilon-a)t} e^{2at} |w|^2 dt \\
&= e^{2(\varepsilon-a)T} \int_0^T e^{2at} |w|^2 dt + 2(a-\varepsilon) \int_0^T e^{2(\varepsilon-a)t} \int_0^t e^{2a\tau} |w|^2 d\tau dt \\
&\leq C e^{2(\varepsilon-a)T} \int_0^T e^{2at} |v|^2 dt + 2C(a-\varepsilon) \int_0^T e^{2(\varepsilon-a)t} \int_0^t e^{2a\tau} |v|^2 d\tau dt \\
&= C \int_0^T e^{2(\varepsilon-a)t} e^{2at} |v|^2 dt \\
&= C \int_0^T e^{2\varepsilon t} |v|^2 dt
\end{aligned}$$

□

Proof of Lemma 4. Given some $h = (w, v)$, $x = \Delta_x(v)$ and $\tau > 0$, let $x_0 = x(\tau)$ and define $h_\tau(t) = (w_\tau(t), v_\tau(t))$ for $t \in [0, \tau]$ according to (15). Let $v_\tau(t) = v(t)$ for $t > \tau$. Then

$$\|P_\tau h_\tau\| \leq c |x(\tau)| \leq c^2 \|P_\tau^{\tau-b} h\| \leq c^2 e^{b-\tau} \|e^t P_\tau h\|$$

□

Proof of Corollary 3. Let the linear time-invariant operator $w = G(v)$ have the minimal state-space realization (A, B, C, D) . By observability of (C, A) there exists a $c > 0$ such that (14) holds. Similarly, by controllability of (A, B) , one can reach $x(\tau + c) = 0$ from some $x(\tau)$ with a bound on v and w in terms of $|x(\tau)|$. By linearity, the same bound can be used in (15). Hence, Lemma 4 can be applied. □

Proof of Lemma 5. By the definition of fading memory, there exists $a, b > 0$ and $C_f > 0$ such that for every $h = (v, \Delta(v))$ and for every $\tau \geq 0$ there exists $h_\tau = (v_\tau, \Delta(v_\tau))$ such that $P_{\tau-b} h_\tau = 0$, $P^\tau h_\tau = P^\tau h$ and

$$\|P_\tau h_\tau\| \leq C_f \|e^{a(t-\tau)} P_\tau h\| \quad (28)$$

Boundedness of Δ implies existence of C such that for all $T > \tau > 0$

$$\begin{aligned}
\|P_T^\tau h\| &\leq \|P_T h_\tau\| + \|P_\tau h_\tau\| \\
&\leq C \|P_T v_\tau\| + \|P_\tau h_\tau\| \\
&\leq C \|P_T^\tau v\| + (C+1) \|P_\tau h_\tau\| \\
&\leq C \|P_T^\tau v\| + (C+1) e^{-a\tau} C_f \|e^{a\tau} P_\tau h\|
\end{aligned}$$

In particular, there exist constants C_0, C_1 , independent of τ and T , such that

$$\int_\tau^T |h|^2 dt \leq C_0 e^{-2a\tau} \int_0^\tau e^{2at} |h|^2 dt + C_1 \int_\tau^T |v|^2 dt \quad (29)$$

for any $\tau \in [0, T]$. Multiplying (29) by $2e^{2\varepsilon\tau}$, where $\varepsilon \in [0, a]$, integrating the products from $\tau = 0$ to $\tau = T$, and adding (29) with $\tau = 0$ to the result yields

$$\int_0^T e^{2\varepsilon t} |h|^2 dt \leq \frac{C_0 \varepsilon}{a - \varepsilon} \int_0^T e^{2\varepsilon t} |h|^2 dt + C_1 \int_0^T e^{2\varepsilon t} |v|^2 dt$$

When $C_0 \varepsilon < a - \varepsilon$, the exponential bound is proved. □

Proof of Theorem 3. We prove the last statement first. From condition (11) and the fading memory of Δ follows that

$$0 \leq \sum_{k=0}^{\infty} \begin{bmatrix} v_k \\ w_k \end{bmatrix}^* \Pi_j(i\omega_k) \begin{bmatrix} v_k \\ w_k \end{bmatrix}$$

for all $w = \Delta(v)$ of the form $v(t) = \text{Re}[\sum_{k=0}^{\infty} v_k e^{i\omega_k t}]$ and $w(t) = \text{Re}[\sum_{k=0}^{\infty} w_k e^{i\omega_k t}]$ with $\sum_k |v_k|^2 < \infty$, $\sum_k |w_k|^2 < \infty$. Using (10) and the equations $v_0 = G(i\omega_0)w_0 + f_0$, $v_k = G(i\omega_k)w_k$ one gets

$$\begin{aligned} 0 &\leq \begin{bmatrix} v_0 \\ w_0 \end{bmatrix}^* \Pi_j(i\omega_0) \begin{bmatrix} v_0 \\ w_0 \end{bmatrix} + \sum_{k=1}^{\infty} \begin{bmatrix} v_k \\ w_k \end{bmatrix}^* \Pi_j(i\omega_k) \begin{bmatrix} v_k \\ w_k \end{bmatrix} \\ &\leq \begin{bmatrix} v_0 \\ w_0 \end{bmatrix}^* \Pi_j(i\omega_0) \begin{bmatrix} v_0 \\ w_0 \end{bmatrix} + \begin{bmatrix} v_k \\ w_k \end{bmatrix}^* \Pi_j(i\omega_k) \begin{bmatrix} v_k \\ w_k \end{bmatrix} \\ &= \begin{bmatrix} w_0 \\ f_0 \\ w_k \end{bmatrix}^* \begin{bmatrix} K_0^j & L_0^j & 0 \\ (L_0^j)' & M_0^j & 0 \\ 0 & 0 & K_k^j \end{bmatrix} \begin{bmatrix} w_0 \\ f_0 \\ w_k \end{bmatrix} \end{aligned}$$

Hence, after multiplying (22) and (23) from right and left by (w_0, f_0) and (w_0, f_0, w_k) respectively, all terms with $j \notin \{0, k\}$ are non-negative because of (10) and can be removed. What remains are the desired inequalities $|w_k| < \gamma|f_0|$. Finally, (20) and (21) are obtained by eliminating the parameters τ_1 and γ analytically. \square

System Analysis via Integral Quadratic Constraints Part IIb: Case studies

A. Megretski

35-418 EECS MIT
Cambridge MA 02139
USA
email: ameg@mit.edu

A. Rantzer

Dept. of Automatic Control
Box 118
S-221 00 Lund
SWEDEN
email: rantzer@control.lth.se

Abstract

The theory developed in Part IIa is here applied in a few case studies. In the first one, it is shown how an unbounded or multi-valued static nonlinearity can be encapsulated in an artificial feedback loop that is suitable for IQC analysis. The second section is devoted to sinusoidal excitation of a system involving saturation. Thirdly, a rate limiter is considered, its L_2 -gain is computed and used for analysis of an example with a PID controller in combination with a rate limiter. Finally, systems with hysteresis are analysed. Such systems do generally not have unique equilibria, but convergence can nevertheless be proved based on exponential decay of signal derivatives.

This is the second part of a paper devoted to stability and performance analysis using integral quadratic constraints. The criteria developed in the first part are here applied to some cases that deserve special attention.

The first case study is devoted to unbounded static nonlinearities that for example appear in friction models. One of them is the ideal relay. The fact that these nonlinearities are unbounded, is an obstacle for direct application of the stability theorem in Part A, but this is resolved by “encapsulating” the nonlinearity in an artificial feedback loop, that is suitable for analysis using integral quadratic constraints.

The second case treats sinusoidal excitation of a system involving saturation. The analysis is performed in three steps. Firstly, it is proved for a range of frequencies of excitation, that the output of the system converges to a periodic signal, with a period length related to the period of excitation. Secondly, uniqueness of the limiting orbit is proved. Finally, the magnitudes of the output harmonics are estimated. In all three steps, there are different restrictions on the integral quadratic constraints that can be used.

The next section is concerned with so called “rate limiters”, where the output of a saturation appears as input of an integrator. Again, a feedback loop needs to

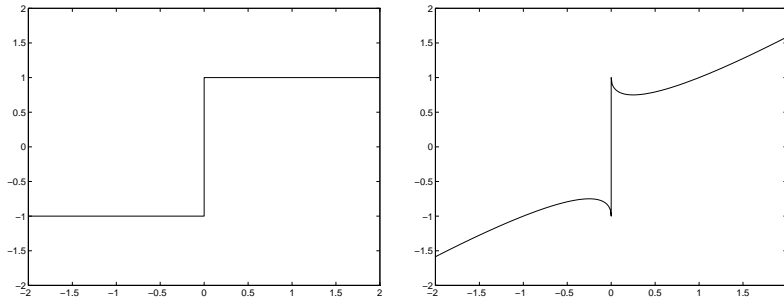

Figure 2 Plots of the operators sgn and cfr

be introduced, in order to obtain a bounded operator suitable for analysis. Moreover, such systems can not be globally exponentially stable, since the saturation gives a global bound on the decay rate of the integrator state. Hence, we have to deal with operators that do not have fading memory.

Finally, one section is devoted to systems with hysteresis, in particular backlash. A characteristic feature of such systems is the presence of many different equilibrium points. In parallel to Yakubovich and Barabanov [10, 1, 2], our objective will therefore be to prove that the *derivatives* of the signals tend to zero, rather than the signals themselves. Moreover, exponential decay of the derivatives is required in order to ensure convergence to a stationary value of the signals. Hence, fading memory is an important features of the operators considered in this section.

8. Encapsulation of static nonlinearities

Consider the classical relay operator $w = \text{sgn}(v)$ defined by

$$\text{sgn}(v) = \{w \in [-1, 1] : vw \geq |v|\},$$

and the “friction” operator $w = \text{cfr}(v)$ defined by

$$\text{cfr}(v) = v + (1 - \sqrt{|v|}) \text{sgn}(v).$$

Operators such as sgn and cfr can not play the role of Δ in the framework for stability analysis developed in Part A, since they are neither continuous nor bounded. Consider, for example, the feedback interconnection of $G(s) = 1/(s+1)$ and $\Delta(v) = -\text{sgn}(v)$. It is easy to see that the operator mapping the interconnection inputs e, f into w is not bounded, because even a small input to sgn may produce large output. Therefore, one cannot prove the input-output stability of this interconnection as long as $\text{sgn}(v)$ is counted among the system outputs, and there is a noisy input to the relay. However, as an alternative point of view, it will be verified that the feedback system

$$\dot{y} = -y - \text{sgn}(y) + v$$

defines an exponentially bounded operator from v to y and \dot{y} . Hence, the choice of inputs and outputs in the system model is important. This phenomenon will be studied in more detail next.

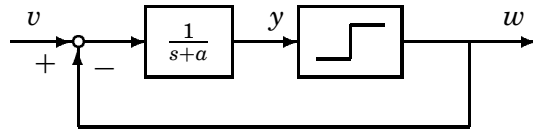

Figure 3 Bounded feedback “encapsulation” of a relay

Let ϕ be a function, that maps real numbers into compact real intervals. It is said to be

- continuous* if $w_i \in \phi(y_i), y_i \rightarrow y, w_i \rightarrow w \Rightarrow w \in \phi(y)$
- positive* if $w \in \phi(y) \Rightarrow wy \geq 0$
- non-decreasing* if $w_1 \in \phi(y_1), w_2 \in \phi(y_2), y_1 > y_2 \Rightarrow w_1 \geq w_2$.

Such functions satisfies the following IQC's, due to Zames, Falb [12] and Popov [9]. A bounded transfer function $H(i\omega) = h_0 + \sum_{k=1}^{\infty} h_k e^{-i\omega T_k} + \int_0^{\infty} h(t) e^{-i\omega t} dt$ is said to belong to *class H* if $h_0 \geq \sum_{k=1}^{\infty} |h_k| + \int_0^{\infty} |h(t)| dt$.

PROPOSITION 2

If ϕ is nondecreasing and odd, while $H \in H$, then

$$0 \leq \int_{-\infty}^{\infty} \hat{w}^* H(i\omega) \hat{y} d\omega \quad \text{for all } w \in \phi(y) \text{ with } y, w \in \mathbf{L}_2$$

$$0 = \int_{-\infty}^{\infty} \hat{w}^* i\omega \hat{y} d\omega \quad \text{for all } w \in \phi(y) \text{ with } y, w, \dot{y} \in \mathbf{L}_2, y(0) = 0$$

□

For $a > 0$, define the operator $w = \Delta_{\phi}^a(v)$ by

$$\begin{cases} \dot{y} = -ay - w + v, & y(0) = 0 \\ w(t) \in \phi(y(t)) \end{cases} \quad (30)$$

See Figure 3. As follows from the next statement, under weak conditions on ϕ , the operator Δ_{ϕ}^a is well-defined and has the features desired in IQC analysis.

THEOREM 4

Let ϕ be a function, that maps real numbers into compact real intervals. If ϕ is continuous and affinely bounded, then for every $a \in \mathbf{R}$, the operator Δ_{ϕ}^a is well-defined and causal. If either $a = 0$ and

$$0 \leq \int_0^{\tau} w(t) dy(t) \quad \forall \tau \in \mathbf{R}, w(t) \in \phi(y(t)) \quad (31)$$

or $a \geq 0$ and ϕ is positive, then Δ_{ϕ}^a is bounded with gain at most one. □

A proof is given in section 13. Note that when ϕ is single-valued, the condition (31) reduces to

$$0 \leq \int_0^y \phi(\sigma) d\sigma \quad \forall y \in \mathbf{R}$$

Two simple applications of Theorem 4 are given next.

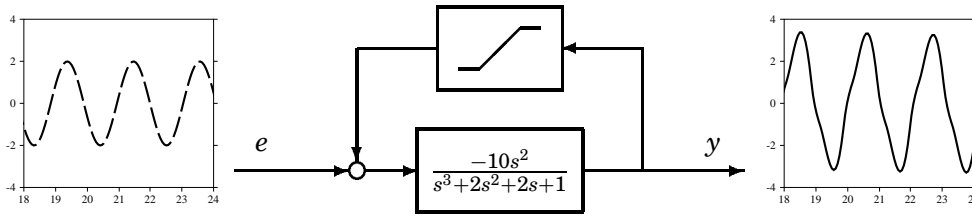

Figure 4 Sinusoidal excitation of system with saturation.

COROLLARY 7

Let $\dot{x} = Ax - B[\sin(Cx) + u]$, $x(0) = 0$ and $G(s) = C(sI - A)^{-1}B$. If $sG(s)$ is stable and

$$0 < \varepsilon < \operatorname{Re} i\omega G(i\omega) \quad \forall \omega \in \mathbf{R} \quad (32)$$

then the operator $u \mapsto \sin(Cx)$ is bounded. \square

Note that if $G(s)$ has a pole at $s = 0$, then the system may have several equilibria x_1, x_2, \dots with $\sin(Cx_k) = 0$ for each of them.

COROLLARY 8

Let $G(s) = C(sI - A)^{-1}B$ with A Hurwitz and let ϕ be continuous, odd, non-decreasing and affinely bounded. If there exist $\varepsilon > 0$, $\eta \in \mathbf{R}$ and $H \in H$ such that

$$\varepsilon < \operatorname{Re}([H(i\omega) + i\omega\eta]G(i\omega)) \quad \forall \omega \in \mathbf{R} \quad (33)$$

$$\varepsilon \leq \operatorname{Re} \frac{H(i\omega) + i\omega\eta}{1 + i\omega} \quad \forall \omega \in \mathbf{R} \quad (34)$$

then for every x_0 the equation $\dot{x} = Ax - B\phi(Cx)$, $x(0) = x_0$ has an absolutely continuous solution and all such solutions are square integrable. \square

This result is different from the one by Zames and Falb [12] in the sense that ϕ is allowed to be unbounded. The condition (33) is unchanged, but the additional restriction (34) is needed in order to complete the proof in the unbounded case.

9. Sinusoidal excitation

To concretize the statements in Part A on systems subject to periodic excitation, we will analyze the system

$$\dot{x} = Ax - B[\operatorname{sat}(Cx) + \sin 2\pi t/T] \quad x(0) = x_0 \quad (35)$$

where

$$C(sI - A)^{-1}B = G(s) = \frac{10s^2}{s^3 + 2s^2 + 2s + 1}$$

The system is illustrated in Figure 4 together with plots of a simulation. Analysis is performed in three steps:

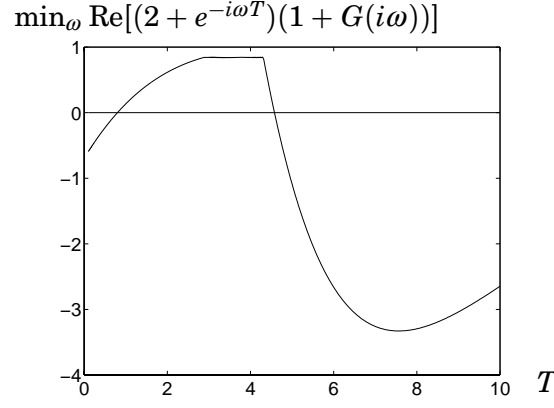

Figure 5 According to the plotted test quantity, periodic inputs with period time between 0.8 and 4.5 will result in system oscillations of the same period

1. Prove convergence to a periodic orbit.
2. Prove uniqueness of the periodic orbit.
3. Estimate the shape of the periodic orbit.

Different types of integral quadratic constraints are used in the different steps of analysis. For the first step, we use the following corollary of Proposition 2.

PROPOSITION 3

If ϕ is nondecreasing and odd with $0 \leq \phi(v)v \leq cv^2$, then

$$0 \leq \int_{-\infty}^{\infty} (\hat{w} - \hat{w}_T)^*(2 + e^{-i\omega T})(\hat{y} - \hat{y}_T)d\omega$$

for all $y = v - w/c$, $w \in \phi(v)$, $\hat{w}_T = e^{-i\omega T}\hat{w}$ and $\hat{v}_T = e^{-i\omega T}\hat{v}$ with $v, w, y \in \mathbf{L}_2$. \square

Proof. Note that $H(i\omega) = 3 - 2e^{i\omega T} - e^{-i2\omega T} = (1 - e^{-i\omega T})^*(2 + e^{-i\omega T})(1 - e^{-i\omega T})$ is of class H . Hence, the statement follows from Proposition 2 and the fact that the operator $y \mapsto w$ is nondecreasing and odd. \square

It is natural to rewrite the system (35) with $e(t) = \sin 2\pi t/T$ and $f(t) = Ce^{At}x_0$ as

$$\begin{cases} v = Gw + f \\ w = \text{sat}(-y) + e \end{cases} \quad \begin{cases} v - v_T = G(w - w_T) + f - f_T \\ w - w_T = \text{sat}(v) - \text{sat}(v_T) + e - e_T \end{cases}$$

Proposition 3 with $c = 1$ gives an IQC for the operator $w - w_T = \Delta(v - v_T) = \text{sat}(v) - \text{sat}(v_T)$. Hence, application of the standard stability criterion (Corollary 4 in Part A), shows that $v - v_T$ and $w - w_T$ are square integrable provided that

$$0 < \varepsilon < \text{Re}[(2 + e^{-i\omega T})(1 + G(i\omega))] \quad \omega \in \mathbf{R}$$

It is easy to check that this condition is fulfilled for $0.8 \leq T \leq 4.5$. See Figure 5. For these values of T , we can therefore conclude that all solutions tend towards a T -periodic behavior.

However, it is also possible to make a conclusion about excitation of higher frequency, i.e. for $T < 0.8$. For such values, since 0.8 is less than half of 4.5 there

will always exist an integer N such that NT is in the interval $[0.8, 4.5]$. The previous argument can therefore be applied with T replaced by NT , to conclude that all solutions tend towards NT -periodicity. This opens the door for so called *sub-harmonic* oscillations. For inputs with $T > 4.5$, no conclusion can be drawn.

The second step of analysis is to verify uniqueness, i.e. that the limiting periodic solutions are independent of the initial state. For this purpose we note that the “stability condition” $\operatorname{Re} G(i\omega) > -1$ holds for $\omega > 0.6$. This turns out to be sufficient, since $0.6 \cdot 4.5 < 2\pi$, so the limiting periodic orbits that we have proved to exist, all have higher frequency than 0.6.

To make this argument rigorous, consider an input with $T < 4.5$ and two corresponding solutions

$$w_1 = \operatorname{sat}(Gw_1 + f_1) \qquad w_2 = \operatorname{sat}(Gw_2 + f_2)$$

with $f_k(t) = Ce^{At}x_k$ for $k = 1$ and $k = 2$. Both w_1 and w_2 tend towards periodic orbits of frequency higher than 0.6, so

$$0 \leq \int_0^\tau [(1 - \varepsilon)(w_1 - w_2) + G(w_1 - w_2)](w_1 - w_2)dt$$

for sufficiently large τ . In addition, the saturation satisfies the corresponding constraint incrementally:

$$0 \geq \int_0^\tau [\operatorname{sat}(v_1) - \operatorname{sat}(v_2) - (v_1 - v_2)][\operatorname{sat}(v_1) - \operatorname{sat}(v_2)]dt$$

Hence, it follows as in (27) in Part A that there exists a constant γ , independent of x_1 and x_2 such that

$$\int_0^\tau |v_1(t) - v_2(t)|^2 dt \leq \gamma |x_1 - x_2| \qquad \forall \tau$$

In particular, the asymptotic periodic orbits are identical and unique.

Finally, it is interesting to simulate the system and compare the actual output with the bounds of Corollary 6 in Part A. With $\omega_0 = 3$, $\omega_1 = 3\omega_0$, the conic condition $\operatorname{sat}(v)[v - \operatorname{sat}(v)] \geq 0$, gives the bounds

$$|b_0|/|a_0| \leq 4.66 \qquad |b_1|/|a_0| \leq 0.95$$

Simulation with gives

$$\begin{array}{lll} |b_0|/|a_0| = 1.53 & |b_1|/|a_0| = 0.18 & \text{for } a_0 = 2 \\ |b_0|/|a_0| \approx 3.33 & |b_1|/|a_0| \approx 0 & \text{for very large } a_0 \end{array}$$

10. Rate limiters

The complications considered in this section are similar to the ones of section 8, but now the problems occur at lower frequencies, while the analysis of relay and friction had high frequency complications. Many systems of practical interest involve a pure integrator controlled by a saturated actuator. Unfortunately, direct application of the stability criteria in Part A is impossible in this situation. For

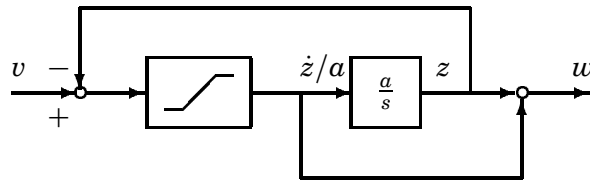

Figure 6 Feedback “encapsulation” of saturation together with integrator

example, consider feedback interconnection of the pure integrator $G(s) = -1/s$ and $\Delta(y) = \text{sat}(y)$. The interconnection is not stable in the L^2 -sense, because the operator $e \rightarrow y$ in

$$\dot{y} = -\text{sat}(y) - e, \quad y(0) = 0$$

is not bounded. However, the system with $e \equiv 0$ is still asymptotically stable.

Again it is possible to analyze the system using a preliminary feedback loop. For this purpose, let the operator $w = \Gamma_{\text{sat}}^a(v)$ be defined by the relations

$$\begin{cases} \dot{z} = a \text{sat}(v - z) & z(0) = 0 \\ w = z + \text{sat}(v - z) \end{cases}$$

where $a > 0$. See Figure 6. Then $v, w \in \mathbf{L}_2$ if and only if $\xi = \text{sat}(y)$ with $\xi, \xi/s, y \in \mathbf{L}_2$ and

$$\begin{cases} y = v - \frac{a}{s+a}w \\ \xi = \frac{s}{s+a}w \end{cases} \quad \begin{cases} w = \frac{s+a}{s}\xi \\ v = y + \frac{a}{s}\xi \end{cases}$$

The operator Γ_{sat}^a is bounded, that satisfies many useful IQC’s:

THEOREM 5

The operator $w = \Gamma_{\text{sat}}^a(v)$ is well-defined, causal and bounded with gain $\sqrt{2}$. It satisfies the IQC’s

$$0 \leq \int_{-\infty}^{\infty} \text{Re} \left[(\hat{v} - \hat{w})H(i\omega) \frac{i\omega}{i\omega + a} \hat{w} \right] d\omega \quad \text{for } H \in \mathcal{H} \quad (36)$$

$$0 = \int_{-\infty}^{\infty} \text{Re} \left[\left(\frac{i\omega}{i\omega + a} \hat{w} \right)^* \left(i\omega \hat{v} - \frac{i\omega a}{i\omega + a} \hat{w} \right) \right] d\omega \quad \text{for } sv \in \mathbf{L}_2 \quad (37)$$

$$0 \leq \int_{-\infty}^{\infty} (2|\hat{v}|^2 - |\hat{w}|^2) d\omega \quad (38)$$

for $v, w \in \mathbf{L}_2$. □

Remark 1 Convex combinations of the IQC’s (36-38) can be used for stability verification in the usual way. However, it should be noted that quadratic forms in (36) and (37) need not be negative definite with respect to w , as required by Corollary 2 in Part A. Hence, either attention should be restricted to convex combinations that satisfy this constraint, or the homotopy assumption of Theorem 2 needs to be addressed some other way. □

The gain value of Γ_{sat}^a can also be interpreted as an IQC for saturation:

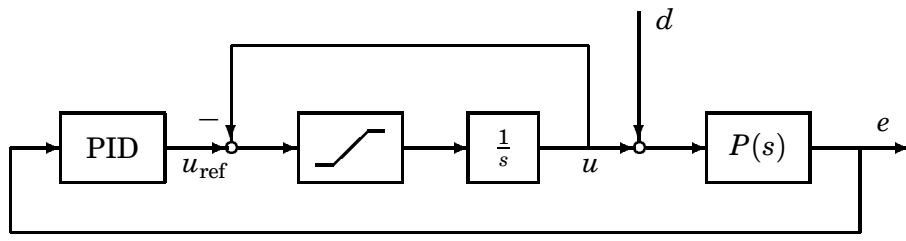

Figure 7 PID control with rate limiter

COROLLARY 9

Every $\xi = \text{sat}(y)$ with $\xi, \xi/s, y \in \mathbf{L}_2$ satisfies

$$2 \left\| y + \frac{a}{s} \xi \right\|^2 - \left\| \xi + \frac{a}{s} \xi \right\|^2 \geq 0$$

□

Unlike most other known IQC's for saturation, this one is quite specific for saturation and will not hold, for example, when sat is replaced by the “dead zone” nonlinearity $\xi = y - \text{sat}(y)$.

The outcome of Theorem 5 is that the stability theory based on integral quadratic constraints can be applied also in situations where saturations in combination with integrators excludes global exponential decay.

Example 2 Rate limiters are common in aircraft applications. A very simple aircraft control loop can have the form

$$\begin{aligned} e &= P(u + d) \\ v &= C e \\ \dot{u} &= \text{sat}(v - u) \end{aligned}$$

where P is the plant, C is the controller, d is a disturbance, v a reference value from the controller, while u is the actual control signal with rate limitation $|\dot{u}| < 1$.

We will now use the previous results to prove that the control loop is stable for

$$\begin{aligned} P(s) &= \frac{1}{s^2 + 2s + 11} \\ C(s) &= K \left(1 + \frac{2.5}{s + 0.01} + \frac{0.3s}{0.01s + 1} \right) \end{aligned}$$

with $K = 40$ and compute an upper bound on the \mathbf{L}_2 -induced gain from d to e . Step responses with various saturation levels in the rate limiter are plotted in Figure 8, both for the stable case $K = 40$ and for the unstable case $K = 80$.

Note that $C(s)$ can be viewed as a PID controller, with leakage in the integrator and a time constant in the derivative parts. In presence of rate limitations, it is advisable to avoid instabilities by introducing an anti-windup scheme in the controller. However, for simplicity of presentation, we analyze the feedback system without anti-windup.

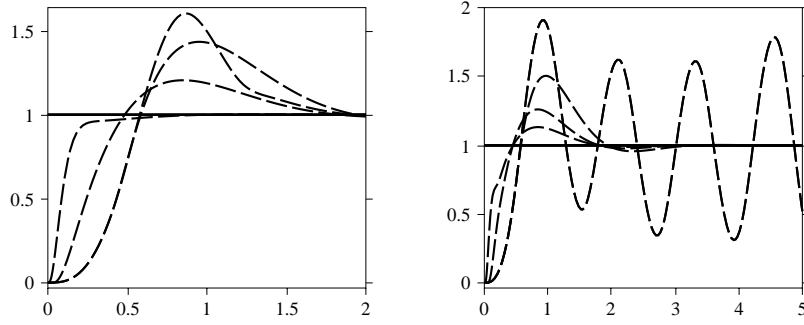

Figure 8 Step responses with various rate limitations for $K = 40$ left and $K = 80$ right.

Define $w = u + \dot{u}$. Then

$$v = CP \frac{1}{s+1} w + CPd$$

The map from v to w is bounded and satisfies a number of integral quadratic constraints (36-38). In particular, it satisfies (36) with $H(s) = 1 \pm (1 \pm s)^{-1}$. A convex combination of these IQC's proves stability and the gain bound $\|e\| \leq 6.74\|d\|$. This has been found numerically using convex optimization in terms of linear matrix inequalities along the lines outlined in [7]. □

11. Backlash and Hysteresis

Another type of difficulty appears in systems with hysteresis nonlinearities. Such interconnections typically have many possible equilibria, so they are unstable in the sense that the signals do not tend to zero. Nevertheless, we will use the previous methods in order to prove exponential decay of the signal derivatives.

Let f_+ and f_- be affinely bounded continuous functions, mapping vectors in \mathbf{R}^n to convex subsets of \mathbf{R}^n . Let $h : \mathbf{R}^n \rightarrow \mathbf{R}$ be a function, and let $U \subset \mathbf{R}^n$ be a set. We say that two scalar signals y, ξ satisfy the *hysteresis relation* defined by f and h (notation $\xi = \text{hys}(y) = \text{hys}_{f,h}(y)$), if $\dot{y} \in \mathbf{L}_{2e}$ and there exists a locally Lipschitz function $x : [0, \infty) \rightarrow \mathbf{R}^n$ such that

$$\begin{aligned} \dot{x} &\in \begin{cases} f_+(x)\dot{y}, & \text{if } \dot{y} \geq 0 \\ f_-(x)\dot{y}, & \text{if } \dot{y} \leq 0 \end{cases} & x(0) \in U \\ \xi(t) &= h(x(t)) \end{aligned} \quad (39)$$

In (39), f_+ and f_- define the admissible trajectories for the phase vector x for the cases when y is respectively increasing or decreasing, while h defines how the possibly higher-dimensional dynamics of x results in variations of the scalar output ξ .

For example, the ideal backlash relation, defined by the condition

$$y - \xi = \text{sgn } \dot{\xi},$$

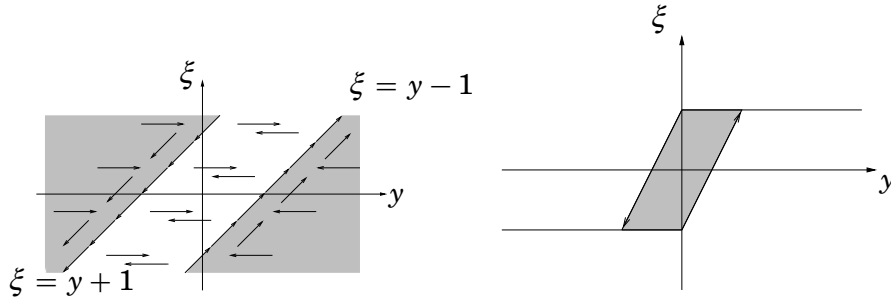

Figure 9 Backlash and magnetic hysteresis

is a special case of (39) with $n = 2$ and

$$\begin{aligned}
 f_{\pm}(x_1, x_2) &= (1, 0.5[1 - \text{sgn}(1 \mp x_1 \pm x_2)]) \\
 h(x_1, x_2) &= x_2 \\
 U &= \{(0, \xi) : |\xi| \leq 1\}
 \end{aligned} \tag{40}$$

See Figure 9. Similarly, it is shown in section 13 that the ideal “magnetic” type hysteresis (Figure 9) also can be represented in the form (39).

PROPOSITION 4

Assume that U is compact, h is a globally Lipschitz function, with Lipschitz constant L , while f_- and f_+ are continuous in the sense defined for Theorem 4 and $|r| \leq R$ for all $r \in \pm f_{\pm}(x)$. Then the set of all pairs $(\dot{y}, \dot{\xi})$, where y and ξ satisfy the hysteresis relation (39), defines a causal and locally *-continuous operator $\dot{y} \rightarrow \dot{\xi}$. Moreover, the operator $\dot{y} \rightarrow \dot{\xi}$ is causal and bounded with the norm not exceeding RL . \square

A proof is given in section 13. Combination with Corollary 4 and Corollary 2 in Part A immediately gives the analog of the circle criterion.

COROLLARY 10

Let the assumptions of Theorem 4 be satisfied and suppose that $\text{hys}_{f,h}$ has fading memory. Let $G(s) = C(sI - A)^{-1}B$. If $RL|G(i\omega)| < 1$ for all ω then \dot{y} and $\dot{\xi}$ tend to zero exponentially for all solutions to

$$\dot{x} = Ax - B\xi, \quad \xi = \text{hys}_{f,h}(y), \quad y = Cx \tag{41}$$

\square

In order to use more constraints for the nonlinearity, we will again encapsulate it by an artificial feedback loop. For $a > 0$, $b > -a$ define the operator $w = \Delta_{\text{hys}}(v)$ by the relations

$$\begin{cases} \dot{y} = -ay + b(v - \xi), & y(0) = 0 \\ \xi = \text{hys}_{f,h,U}(y) \\ w = \dot{\xi} \end{cases} \tag{42}$$

When f , h and D are defined by (40), the operator is denoted Δ_{bkl} . See Figure 10. The operator has properties as follows.

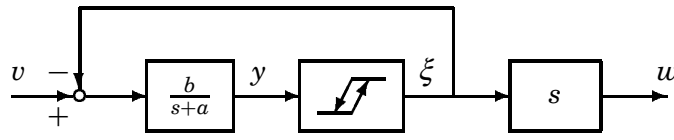

Figure 10 Feedback “encapsulation” of hysteresis

THEOREM 6

The operators $(1/s) \circ \Delta_{\text{hys}}$ and Δ_{hys} are both well-defined and causal. If $a + b\alpha > 0$, where

$$\alpha < \frac{\partial h}{\partial x}(x) f_{\pm}(x) < \beta \quad \forall x \quad (43)$$

then Δ_{hys} is bounded. In addition, the backlash operator $w = \Delta_{\text{bkl}}(v)$ has fading memory, and satisfies the IQC's

$$0 \leq \int_{-\infty}^{\infty} \text{Re} \left[\hat{w}^* \left(\frac{bH(i\omega)}{i\omega + a} (\hat{v} + \hat{w}/a) - (1 + b/a) \frac{H(i\omega) - H(0)}{i\omega} \hat{w} \right) \right] d\omega \quad (44)$$

$$0 = \int_{-\infty}^{\infty} \text{Re} \left[\hat{w}^* \left(\frac{bi\omega}{i\omega + a} \hat{v} - \frac{b}{i\omega + a} \hat{w} - \hat{w} \right) \right] d\omega \quad (45)$$

for every $H \in \mathcal{H}$. □

In particular, this gives the following stability criterion for systems with backlash.

COROLLARY 11

Let $G(s) = C(sI - A)^{-1}B$. If there exist $\varepsilon > 0$, $\eta \in \mathbf{R}$ and $H \in \mathcal{H}$ such that

$$G(0) > -1 \quad (46)$$

$$\text{Re} \left[(G(i\omega) + 1) \left(\eta + \frac{H(i\omega)}{i\omega} \right) \right] > \varepsilon \quad \forall \omega \neq 0 \quad (47)$$

then for the solutions of (41) with f, h, U corresponding to backlash, the derivatives $\dot{\xi}$ and \dot{y} tend to zero exponentially. □

Example 3 The “Popov plot” corresponding to $G(s) = 300(s + 1)^{-1}(s + 10)^{-1}$ is shown in Figure 11. It can be seen that the condition (46-47) holds with $H(s) \equiv 1$ provided that η is a sufficiently small. Hence, in the system

$$\begin{aligned} \dot{x}_1 &= -x_1 + \xi \\ \dot{x}_2 &= -10x_2 + x_1 \\ \xi &= \text{hys}_{\text{bkl}}(-300x_2) \end{aligned}$$

$\dot{\xi}$ and \dot{x} tend to zero exponentially. □

Finally, we note that ideal “magnetic” hysteresis (Figure 9) can be represented in the form (39) with f_{\pm}, h, U defined as follows. See Figure 12. Let

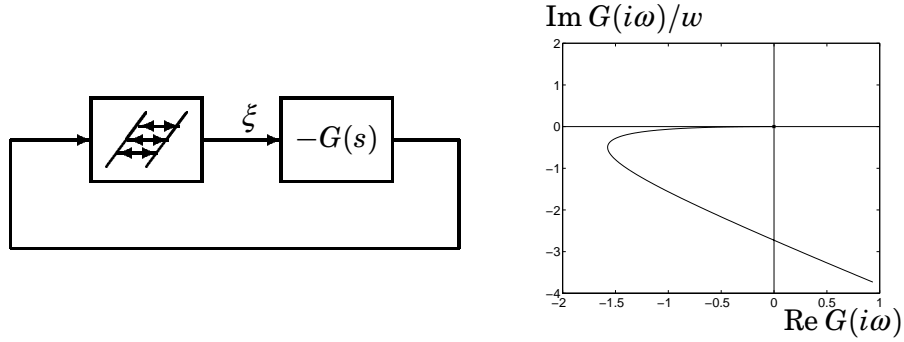

Figure 11 Feedback loop in Example 11 with corresponding Popov plot

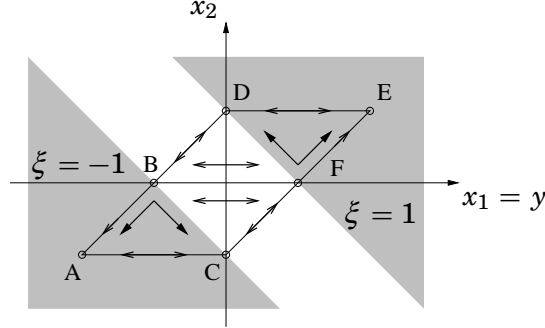

Figure 12 State space model of magnetic hysteresis

A, B, C, D, E, F be the points in \mathbf{R}^2 with coordinates $A = (-2, -1)$, $B = (-1, 0)$, $C = (0, -1)$, $D = (0, 1)$, $E = (2, 1)$, $F = (1, 0)$. Then

$$\begin{aligned} f_+(x_1, x_2) &= (1, f_{2+}(x_1, x_2)) \\ f_-(x_1, x_2) &= (1, f_{2+}(-x_1, -x_2)) \\ h(x_1, x_2) &= \text{sat}(x_1 + x_2) \\ U &= \{(0, 1), (0, -1)\} \end{aligned}$$

where

$$f_{2+}(x_1, x_2) = \begin{cases} [0, 1] & \text{on the segments } [BD], [CE], [DF] \text{ and } [DE] \\ 1 & \text{in the interior of the triangle } [DFE] \\ -1 & \text{in the interior of the triangle } [ABC] \\ [-1, 0] & \text{on the boundary of triangle } [ABC] \\ 0 & \text{otherwise} \end{cases}$$

12. Conclusions

A variety of nonlinear systems have been analysed using integral quadratic constraints. The approach has been based on the introduction of bounded causal operators defined in terms of artificial feedback loops.

We believe that that this approach can be extended to a large number of other cases: Once a gain bound has been obtained for a given component, possibly interconnected in an artificial feedback loop, this gain bound can be used in the general computational framework of integral quadratic constraints.

13. Proofs

Proof of Proposition 2. The original proofs of [12] and [9] go through unchanged. Here follows the main argument of [12]. Define $P(x) = \int_0^x \phi(s)ds$ and note that

$$x\phi(x) - y\phi(y) = (x - y)P'(x) \geq P(x) - P(y) \quad \text{a.e.}$$

$$\int_{-\infty}^{\infty} [v(t)\phi(v(t)) \pm v(t - \tau)\phi(v(t))]dt \geq \int_{-\infty}^{\infty} [P(v(t)) - P(\mp v(t - \tau))]dt = 0$$

Let $H(s) = D + C(sI - A)^{-1}B$. Then

$$\begin{aligned} \int_{-\infty}^{\infty} \widehat{w}^* H(i\omega) \widehat{v} d\omega &= \int_0^{\infty} \phi(v(t)) \left[Dv(t) + \int_0^{\infty} C e^{\tau A} B v(t - \tau) d\tau \right] dt \\ &\geq \left[D - \int_0^{\infty} |C e^{\tau A} B| d\tau \right] \int_0^{\infty} \phi(v(t)) v(t) dt \geq 0 \end{aligned}$$

□

Proof of Theorem 4. By Theorem 1 in Part A, the operator Δ_ϕ^a is well-defined and causal. If $a \geq 0$ and ϕ is positive, then

$$\begin{aligned} \int_0^T (w^2 - v^2) dt &\leq 2 \int_0^T w(w - v) dt \\ &= -2 \int_0^T w(\dot{y} + ay) dt \\ &\leq -2 \int_0^{y(T)} w dy(t) \leq 0 \end{aligned}$$

If $a = 0$, then $V(y) = 2 \int_0^y \phi(\sigma) d\sigma$ gives

$$\frac{\partial V(y(t))}{\partial t} = 2w\dot{y} = 2w(-w + v)$$

$$\begin{aligned} \int_0^T (|v|^2 - |w|^2) dt &= \int_0^T [2w(-w + v) + (-w + v)^2] dt \\ &\geq \int_0^T \frac{\partial V(y(t))}{\partial t} dt = V(y(T)) > 0 \end{aligned}$$

□

Proof of Corollary 7. The equation $\dot{x} = Ax - B[\sin(Cx) + u]$, $x(0) = 0$, can be

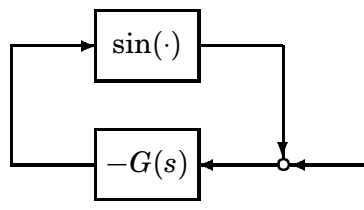

Figure 13 Feedback loop with sinusoidal nonlinearity

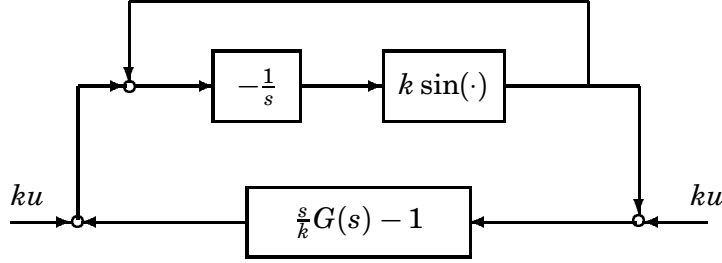

Figure 14 Equivalent feedback loop with sinusoidal nonlinearity

rewritten, see Figure 13 and Figure 14, with $y = Cx$ and $w = k \sin(y)$ as

$$y = -G(s)[\sin(y) + u]$$

$$\begin{cases} v = - \left[\frac{1}{k} s G(s) - 1 \right] (w + ku) - ku \\ \dot{y} = v - w \end{cases}$$

$$\begin{cases} w = \Delta_{k \sin}^0(v) \\ v = - \left[\frac{1}{k} s G(s) - 1 \right] (w + ku) - ku \end{cases}$$

The gain of $\Delta_{k \sin}^0$ is at most one, so the result follows from the small gain theorem, since by (32), the gain of $sG(s)/k - 1$ is less than one for sufficiently large k . \square

Proof of Corollary 8. The system can be written on the form

$$\begin{cases} v = [-(s+1)G(s) + 1]w - f \\ w = \Delta_{\phi}^1(v) \end{cases}$$

where $f(t) = (CA + C)e^{At}x_0$. Solutions exist by Theorem 1 in Part A. To convert the IQC's for ϕ from Proposition 2 into IQC's for Δ_{ϕ}^1 , note that $w = \Delta_{\phi}^1(v)$ with $v, w \in \mathbf{L}_2$ if and only if $y, w, \dot{y} \in \mathbf{L}_2$, where

$$y = \frac{1}{s+1}(v - w) \quad v = \dot{y} + y + w$$

Hence, Δ_{ϕ}^1 satisfies the IQC

$$0 \leq \int_{-\infty}^{\infty} \hat{w}^* [H(i\omega) + i\omega\eta] \frac{1}{i\omega + 1} (\hat{v} - \hat{w}) d\omega \quad (48)$$

for all $\eta \in \mathbf{R}$ and the desired result follows from Corollary 4 in Part A. Note that (34) is needed to ensure that the quadratic form in (48) is negative definite in w . \square

Proof of Theorem 5. Theorem 1 in Part A shows that the operator Γ_{sat}^a is well-defined and causal. The parameter a only defines the time scale and does not affect the gain, so consider the case $a = 1$ without loss of generality. Let $V(z) \geq 0$ be the Lyapunov function defined by

$$\frac{dV}{dz}(z) = \begin{cases} 4z & \text{for } |z| \leq 1 \\ (1 + |z|)^2 z / |z| & \text{for } |z| \geq 1 \end{cases} \quad V(0) = 0$$

First, we will verify that

$$-\frac{dV}{dz}(z) \text{sat}(v - z) + 2|v|^2 - |z + \text{sat}(v - z)|^2 \geq 0 \quad \forall z, v \quad (49)$$

Given a fixed z , consider the minimum of the left hand side in (49). There are two possibilities. Either the saturation occurs at the optimum. Then all terms except $|v|^2$ are locally independent of v , the minimum must be at $v = 0$ and the minimal value is nonnegative. The other possibility is that saturation does not occur. Then the left hand side is quadratic in v and the minimum zero is attained at $v = z - 1$ if $z < -1$, at $v = 2z$ if $|z| \leq 1$ and at $v = z + 1$ if $|z| > 1$.

Integrating (49) over the time interval $[0, T]$ gives

$$\int_0^T (2|v|^2 - |z + \text{sat}(v - z)|^2) dt \geq V(z(T)) \geq 0$$

This proves that $\|\Delta_{\text{sat}}^a\| \leq \sqrt{2}$.

The opposite inequality $\|\Gamma_{\text{sat}}^a\| \geq \sqrt{2}$ follows by considering the inputs

$$v(t) = \begin{cases} 1 + t & \text{for } 0 \leq t \leq T \\ 0 & \text{for } t > T \end{cases}$$

where $T \rightarrow \infty$. \square

Proof of Proposition 4. That the hysteresis relation (39), defines a causal and locally *-continuous operator $\dot{y} \rightarrow \dot{\xi}$, follows directly from Theorem 1 in Part A with $v = (0, \dot{y})$ and $F(z_1, z_2) = (\frac{1}{s} \circ F_0(z_1, z_2), z_2/2)$, where

$$F_0(z_1, z_2) \in \begin{cases} f_+(z_1)z_2 & \text{if } z_2 \geq 0 \\ f_-(z_1)z_2 & \text{if } z_2 \leq 0 \end{cases}$$

The causality and boundedness of the operator $\dot{y} \mapsto \dot{\xi}$ follows immediately by the relation $\dot{\xi} = \frac{\partial h}{\partial x} F_0(x, \dot{y})$. \square

Proof of Theorem 6. That $(1/s) \circ \Delta_{\text{hys}}$ is well-defined and causal follows directly from Theorem 1 in Part A. Hence the map $v \mapsto \dot{\xi}$ is causal and therefore also the map $v \mapsto \dot{y} \mapsto \dot{\xi}$.

For the boundedness, note that (43) implies that $\dot{\xi}(t) = k(t)y(t)$ with $k(t) \in [\alpha, \beta]$ for all t . Hence with $z = \dot{y} - bv$

$$\begin{aligned} \dot{y} + ay + b\xi &= bv \\ \dot{y} + [a + bk(t)]\dot{y} &= b\dot{v} \\ \dot{z} + [a + bk(t)]z &= -b[a + bk(t)]v \\ \|z\| &\leq \frac{a + b\beta}{a + b\alpha} b \|v\| \\ \|w\| = \|\dot{\xi}\| &\leq \beta \|\dot{y}\| \leq \beta (\|z\| + b\|v\|) \leq \beta b \left(1 + \frac{a + b\beta}{a + b\alpha}\right) \|v\| \end{aligned}$$

The fading memory of Δ_{bkl} follows from Lemma 2 in Part A. To verify the IQC's, note that

$$0 \leq \dot{\xi}(t)(y - \xi)(t) \quad \forall t$$

In addition, $\dot{\xi}(t)$ can be nonzero only if $|y(t) - \xi(t)| = 1$. It is therefore possible to add perturbations to the factor $y - \xi$ without violating the inequality. More precisely,

$$0 \leq \dot{\xi}[y - \xi + h * (y - \xi)] \quad \forall t$$

for every convolution kernel h with $\int_{-\infty}^{\infty} |h|dt \leq 1$, because the magnitude of the term $h * (y - \xi)$ is then at most one. Noting that $\langle \dot{\xi}, \xi \rangle = 0$ for $\xi, \dot{\xi} \in \mathbf{L}_2$ gives

$$\begin{aligned} 0 &\leq \langle \dot{\xi}, y - \xi + h * (y - \xi) \rangle \\ &= \langle w, [1 + H(s)]y - \xi \rangle \\ &= \langle w, [1 + H(s)](y - \xi) + [1 + H(0)](1 + b/a)\xi \rangle \\ &= \langle w, [1 + H](y + \xi b/a) \rangle - \langle w, [H - H(0)](1 + b/a)\xi \rangle \\ &= \left\langle w, \frac{b[1 + H(s)]}{s + a}(v + w/a) \right\rangle \\ &\quad - (1 + b/a) \left\langle w, \frac{H(s) - H(0)}{s} w \right\rangle \end{aligned}$$

The equality (45) follows by noting that

$$\begin{aligned} 0 &= \langle \dot{\xi}, \dot{y} - \dot{\xi} \rangle \\ &= \left\langle w, \frac{bs}{s + a}v - \frac{b}{s + a}w - w \right\rangle \end{aligned}$$

□

Proof of Corollary 11. Let $b = aG(0)$. Then $b > -a$ so Δ_{bkl} is properly defined and the transfer function

$$G_1(s) := \left[1 - \frac{s + a}{b}G(s)\right] / s$$

is stable because the b was chosen to cancel the unstable pole. From (41) and (42) follows that

$$\begin{cases} v = G_1(w) + b^{-1}(aC + CA)e^{At}x(0) \\ w = \Delta_{\text{bkl}}(v) \end{cases}$$

so to conclude exponential decay of $\dot{\xi}$ and \dot{y} , it is sufficient to verify the condition on G in Corollary 4 of Part A, with Π corresponding to a convex combination of (44) and (45). This condition becomes the inequality (47). \square

14. Acknowledgements

The work has been supported by the Swedish Research Council for Engineering Sciences, grant 94-716. Travelling grants from Swedish Natural Science Research Council and the Nils Hörjel Research Fund at Lund University have been instrumental for the cooperation between the authors. Finally, thanks to a number of colleagues, who have contributed with useful comments and suggestions on the work.

15. References

- [1] N.E. Barabanov and V.A. Yakubovich. Absolute Stability of Control Systems with one Hysteresis Nonlinearity. *Avtomatika i Telemekhanika*, 12:5–12, December 1979. (English translation in Autom. and Remote Control.).
- [2] Nikita E. Barabanov. Criteria for global asymptotics of stationary sets of systems containing a hysteresis nonlinearity. *Differential Equations*, 25(5):739–748, 1989. (in Russian).
- [3] C.A. Desoer and M. Vidyasagar. *Feedback Systems: Input-Output Properties*. Academic Press, New York, 1975.
- [4] J. C. Doyle. Analysis of feedback systems with structured uncertainties. In *IEEE Proceedings*, volume D-129, pages 242–251, 1982.
- [5] T. Georgiou and M. Smith. Distance measures for uncertain nonlinear systems. In *Proceedings of 3rd European Control Conference*, page 1016, 1995.
- [6] A. Megretski and A. Rantzer. System analysis via Integral Quadratic Constraints, part I. Technical report, Department of Automatic Control, Lund Institute of Technology, April 1995. In press for publication in *IEEE Transactions on Automatic Control*, June 1997.
- [7] A. Megretski and A. Rantzer. System analysis via Integral Quadratic Constraints. *IEEE Transactions on Automatic Control*, 47(6):819–830, June 1997.
- [8] A. Packard and J.C. Doyle. The complex structured singular value. *Automatica*, 29(1):71–109, 1993.
- [9] V.M. Popov. Absolute stability of nonlinear systems of automatic control. *Automation and Remote Control*, 22:857–875, March 1962. Russian original in August 1961.
- [10] V.A. Yakubovich. The method of matrix inequalities in the theory of stability of non-linear controlled systems. III. Absolute stability of systems with hysteresis non-linearities. *Avtomaika i Telemekhanika*, 26(5):753–763, 1965. (English translation in Autom. Remote Control).

- [11] V.A. Yakubovich. On an abstract theory of absolute stability of nonlinear systems. *Vestnik Leningrad Univ. Math.*, 10:341–361, 1982. Russian original published in 1977.
- [12] G. Zames and P.L. Falb. Stability conditions for systems with monotone and slope-restricted nonlinearities. *SIAM Journal of Control*, 6(1):89–108, 1968.